

# HJ SERIES DESIGNER'S MANUAL



- General Description •
- Performance Calculations •
- Propulsive Efficiency •
- Engine & Gearbox Selection •
- HJ Series Dimensions •
- Scope of Supply •
- Installation Guidelines •
- Driveline Requirements •
- Control Systems •
- Material Specifications •



# The HamiltonJet Promise

## Total Waterjet Solutions

With experience spanning six decades, HamiltonJet provides a totally integrated waterjet propulsion solution to the marine industry. From initial enquiry through the lifespan of a vessel, HamiltonJet offers a comprehensive customer support package that is second to none.

We want your waterjet vessel to be the most successful it can be. To achieve this HamiltonJet will work with you through every stage of the project.

Waterjet propulsion offers many advantages over conventional and alternative forms of marine propulsion. However, it must be acknowledged that waterjets may not be the best solution for your vessel, so it is important you receive the best advice.

This **Designer's Manual for HJ Series Waterjets** is part of the commitment we make to all our valued customers. It will help guide you in making informed decisions about your vessel's propulsion system by answering several key questions...

- Are waterjets a viable option?
- If so, what size waterjet will I need?
- How much room will it require in the hull?
- What is supplied with the waterjet?
- How is the waterjet installed?
- What are the driveline requirements?
- What are the control system requirements?

Please understand this Designer's Manual is a guide only. It is still very important you work closely with HamiltonJet representatives who can provide you with in-depth and specific performance analysis, case study reviews and quality advice and information.

We suggest you fill out and submit the Application Questionnaire form found at the back of the HJ Series sales brochure or at:

[www.hamiltonjet.co.nz/contact\\_us](http://www.hamiltonjet.co.nz/contact_us)

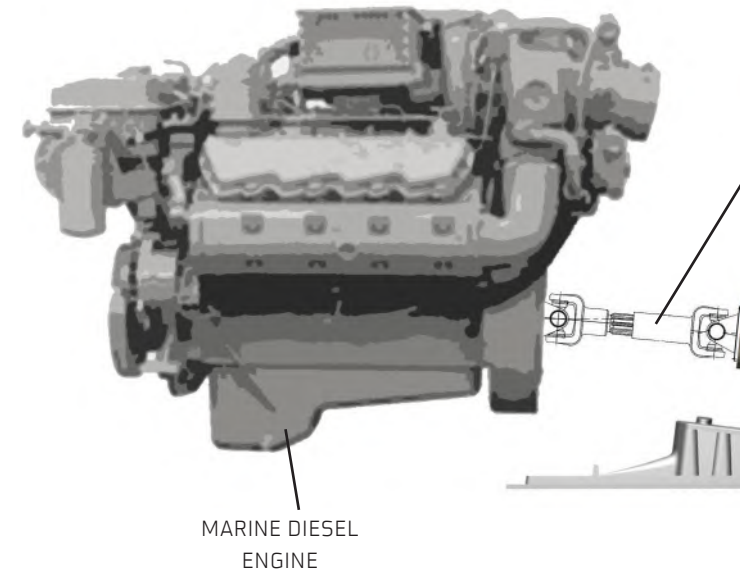

## HJ Series General Description

HamiltonJet waterjets are an advanced marine propulsion system suitable for a wide variety of high and low speed applications. The waterjet utilises a highly developed water pump to generate a high velocity jet of water which, when expelled out the stern of a vessel, generates a thrust force in the opposite direction to push the vessel forward.

The waterjet mounts inboard at the stern, drawing water through an intake fixed to the hull bottom. The intake is protected by a screen which, at planing speeds, is largely self-cleaning. An intake screen rake is optional for improved cleaning ability.

The jet unit passes through the transom via a circular seal and water is discharged directly aft through the outlet nozzle. All thrust forces are transmitted through the intake base to the hull (not transmitted to either the transom or the engine via the driveshaft).

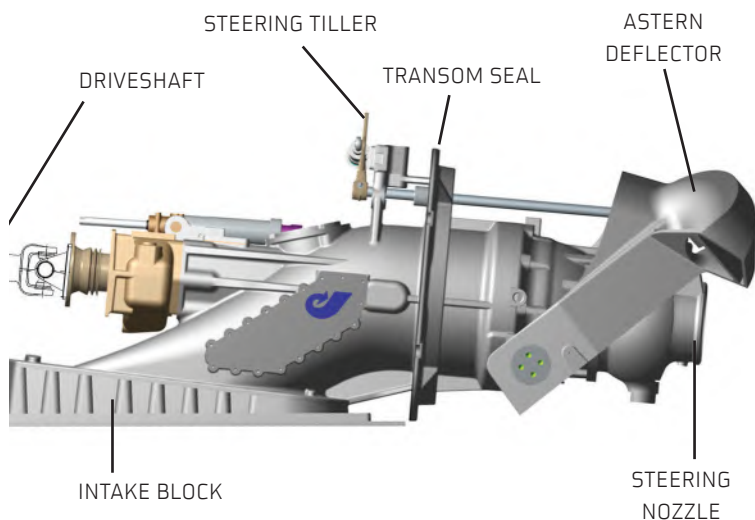

A steerable nozzle deflects the jetstream to port and starboard, providing powerful and responsive steering. Steering is actuated via an inboard mounted tiller. Several different steering control systems are available depending on the jet model, ranging from rotary cable controls to fully integrated electronic control systems.

A split-duct astern deflector is mounted aft of the steering nozzle, providing an infinite range of ahead, zero-speed and astern manoeuvring. Control for the deflector is integrated within the waterjet package through a hydraulic control system, which includes a jet unit mounted and driven hydraulic powerpack (JHPU) and oil cooler integral with the waterjet intake, eliminating the need for an external cooling supply.

When the waterjet is running, full steering is available, regardless of the astern deflector position, i.e. regardless of vessel speed or direction. By working reverse and steering in unison, a resultant thrust can be obtained in any direction giving 360° manoeuvring.

HamiltonJet HJ Series waterjets are normally driven by a high speed marine diesel engine and may be used in both planing and displacement craft. They may also be used as high speed boost propulsion in certain situations. With its computer aided hydrodynamic design, the HamiltonJet waterjet provides high propulsive efficiencies, at least equivalent to propeller systems at planing speeds of 25+ knots. Any number of jets can be employed without loss of propulsive efficiency as there is no additional appendage drag.

\* The HJ212 waterjet does not include sacrificial anodes, so is unsuitable for prolonged or consistent use in a salt water environment. We recommend using the HJ213 waterjet for vessels predominantly used in salt water.

Designed and manufactured to international standards, each HamiltonJet HJ Series waterjet uses corrosion resistant materials which are further protected by a system of sacrificial anodes\*. The units are supplied factory tested as a complete package with integral steering and reverse control systems.

Installation is simplified with an aluminium intake block supplied with each jet. This is fixed in the hull to form the correct jet inlet shape and provide a mounting flange for the jet unit assembly. Intake can be either the standard 5° (positions the jet at 5° to the hull bottom to allow close direct drive coupling of the engine) or with some jet models an optional 0° intake is available. This positions the jet parallel to the hull bottom, allowing a reduced engine installation height when using a drop-centre gearbox.

The intake block is welded into aluminium hulls, bolted into steel hulls or moulded into GRP or wooden hulls. The GRP version eliminates the need for boat builders to mould a thick GRP block, saving time and money.

For many applications a reduction gearbox is not necessary as the waterjet may be directly driven by a large number of common marine engines. The engine should be left-hand rotation (anti-clockwise when looking on the flywheel).

Extensively tested in both HamiltonJet's Hydrodynamic Test Facility and operational vessels, the HamiltonJet HJ Series waterjet is an ideal propulsion system for a wide range of work and patrol boats, and pleasure craft, requiring proven performance and reliability.

# HJ Series Performance Calculations

Performance of any marine vessel depends on several key factors and how they affect each other. These factors include...

- Hull resistance
- Engine power at different rpm levels
- Size and number of propulsors

At HamiltonJet we can accurately predict vessel performance using specialist computer software, provided the information we receive from the designer, builder and engine supplier is accurate to the finished vessel. For any new vessel built to be propelled by HamiltonJet waterjets, we will provide a detailed performance prediction to assist with waterjet sizing, engine & gearbox selection and hull modifications that may be required. It can also assist with diagnosing performance problems when the boat is in operation to reduce costs and time involved.

While any prediction made is no guarantee of a vessel's end performance, HamiltonJet's application engineering experience is well proven in the field. Unlike some other propulsion system manufacturers, we apply a number of safeguards in our calculations to counter the possibility of the finished vessel being outside preliminary design specifications. This ensures the vessel is still able to achieve its desired performance.

Anyone considering using HamiltonJet waterjets for their high speed vessel (over 25 knots) can complete some preliminary performance calculations themselves. By using basic information you can get a general idea of number and size of waterjets required for your vessel, and the engine power required to reach certain speeds.

Please note all waterjet sizing calculations done from the information provided on the following pages do not take into account other factors influencing waterjet selection such as efficiency, cavitation resistance, bollard pull and manoeuvrability requirements.

**Note:** calculations for multi-hull, slower speed or displacement speed vessels are somewhat more complicated and will need specialist input from HamiltonJet and the boat designer to make an accurate prediction.

To help guide you through the calculations shown on the following pages we will use an example vessel with the following specifications...

- Waterline Length: 12.0m
- Beam: 4.2m
- All Up Laden Weight: 12,000kg
- Max. Speed @ AUW: 35 knots

**Note:** For simplicity, other aspects of hull design that can have a significant influence on a vessel's hull resistance and thus performance and propulsion selection are not taken into account in the calculations included in this Designer's Manual. These include hull deadrise angle, longitudinal centre of gravity and windage. HamiltonJet will consider these factors during its Application Engineering process, so final jet selection may differ from any conclusions made here.

## Number and Size of Waterjet Required

Knowing the **maximum displacement** of your vessel, use the chart below to identify the options for size and number of waterjets you will need. Eg: our vessel's maximum displacement will be 12,000kg, so our waterjet options are triple or quad HJ241s, triple HJ274s, twin or triple HJ292s, twin HJ322s or HJ364s, or a single or twin HJ403 waterjets.

**Note:** In general smaller high speed vessels will use single or twin waterjets of a larger size than triple waterjets of a smaller size. It may also be an option to use triple or quadruple HJ series waterjets rather than twin units of the larger HM series. Consult your HamiltonJet Distributor to discuss all options and the advantages / disadvantages of each.

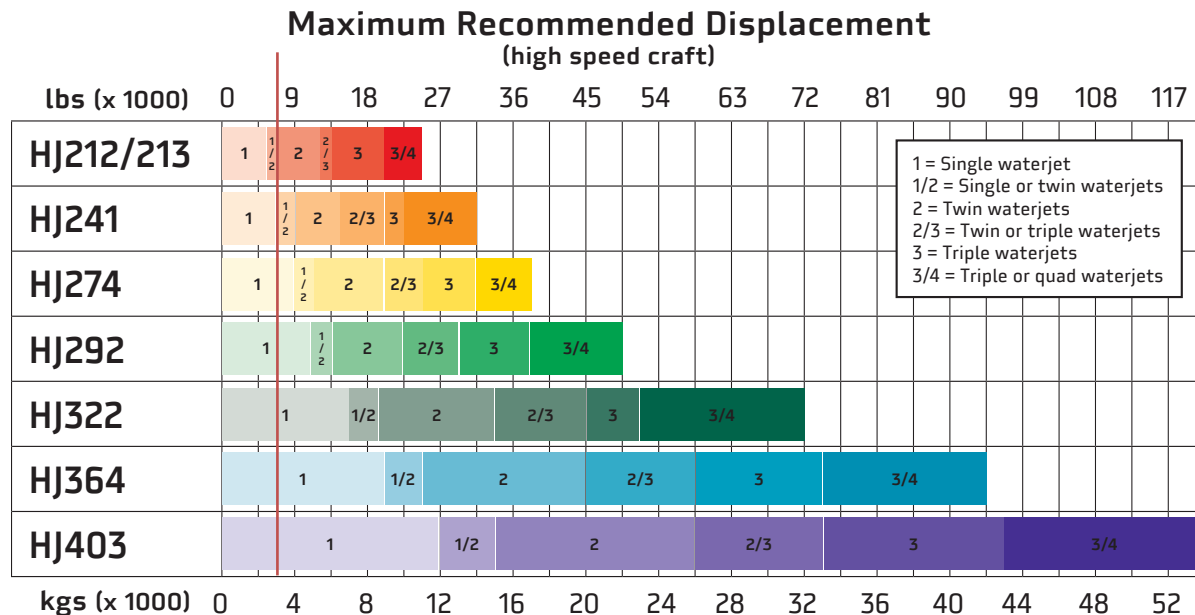

Each block indicates MAXIMUM recommended displacement range.  
 Note: Multiply weight ranges shown by 2 to get Maximum Recommended Displacement for slow speed craft.

# HJ Series Performance Calculations

## Power Required Per Waterjet

Knowing the **speed required at maximum displacement** of your vessel, use the diagram below to calculate the approximate Power to Weight Ratio required for the speed and length of the vessel.

**Note:** this table is an approximate guide to boat speed only, and does not consider variations in hull parameters which directly affect hull resistance - you must consult HamiltonJet for more accurate assessment.

### Speed Guide Table for High Speed Craft

(Use to determine required Power/Weight Ratio)

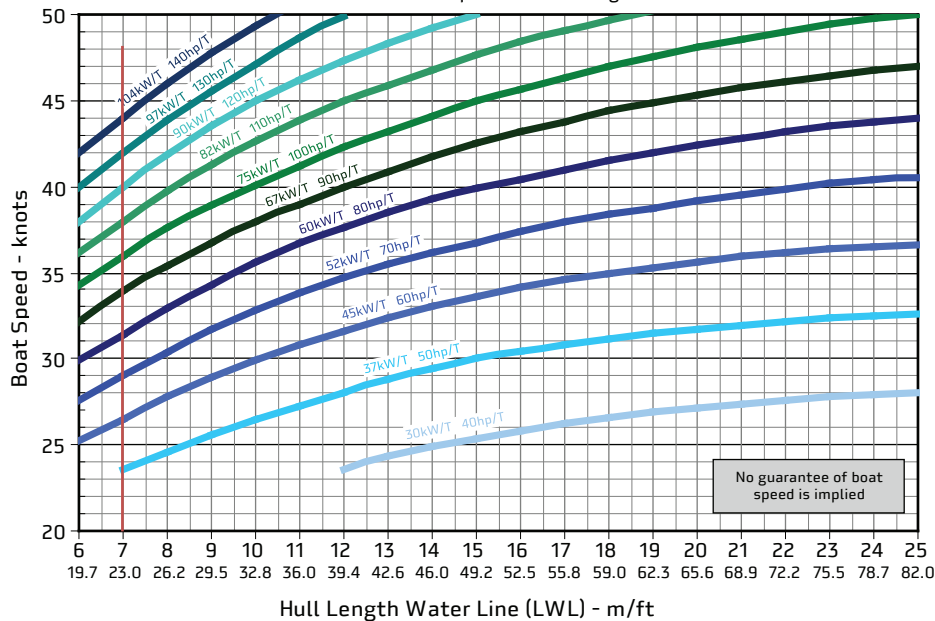

### Power Required per Waterjet

$$= \frac{\text{Power to Weight Ratio (kW/T or hp/T)} \times \text{AUW (Tons)}}{\text{Number of Waterjets}}$$

Using our example 12m vessel and the requirement of 35 knots, we need at least 52kW / 70hp per tonne to achieve this speed. In theory with a 12 tonne hull this would calculate to 630kW / 840hp total power or 360kW / 420hp per waterjet in a twin jet vessel. However, because our bottom loading calculation (see graph at right) is well within 100kg/m<sup>2</sup> of the overladen line, we will likely require more power to achieve speed. As a rule of thumb in this situation add 10hp/T.

## Understanding the Risk of Over Loading

Waterjet propulsion is more sensitive to weight changes in a vessel than other forms of propulsion. In many cases this can be a major advantage in speed and efficiency, however if the weight is significantly increased it can result in poor speed performance, inability to get on the plane and unsuitability of waterjet propulsion.

The first step to avoiding this issue is to determine if the bottom loading limit of your vessel makes it suitable for planing with waterjet propulsion. The Monohull Bottom Loading Limit diagram below can give you an indication of this.

If the boat is suitable for planing it becomes important the designer and builder are fully aware that any increase in AUW during the build will increase bottom loading and push the vessel towards the overladen area. Not only could this make the vessel unsuitable for planing but it will also mean the initial waterjet sizing may no longer be applicable.

### Monohull Bottom Loading Limit (Planing Speed Vessels)

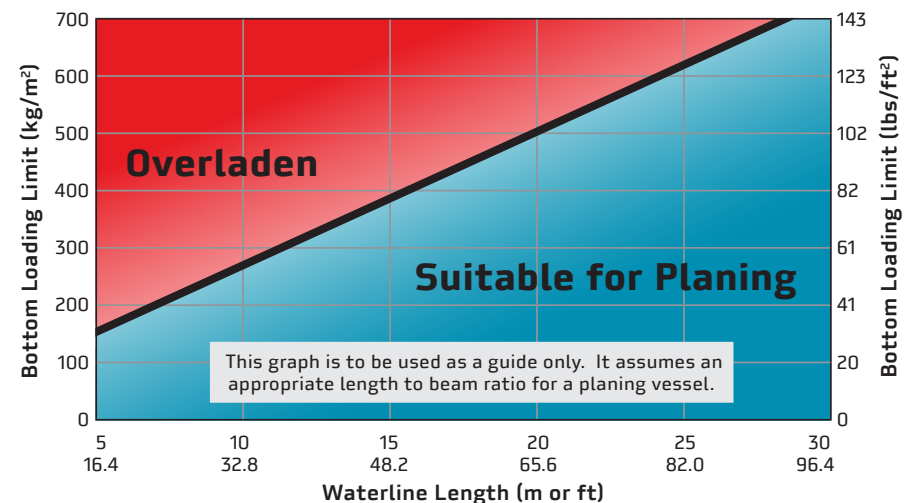

$$\text{Loading (kg/m}^2 \text{ or lbs/ft}^2\text{)} = \frac{\text{AUW (kg or lbs)}}{\text{LWL} \times \text{BPX (m}^2 \text{ or ft}^2\text{)}}$$

# HJ Series Propulsive Efficiency

## Making the Most Efficient Selection

By using the calculations from the previous pages you will have determined likely waterjet size options for your vessel, and from this have an idea of the engine power you will require. Now you can look more closely at propulsive efficiency to further narrow down your waterjet selection options.

In general, propulsive efficiency is affected by the size of the propulsor - larger is more efficient with the same engine power input. However, it is important to consider other design factors of any propulsion system which can directly affect its efficiency at certain vessel speeds.

For example, some propulsion systems are designed to operate most efficiently at speeds above 40 knots, while others perform best below 20 knots. In these situations the high speed propulsor will be less efficient at lower boat speeds, while the low speed propulsor may not even be capable of achieving much higher speeds. In the case of waterjets, intake and impeller/pump design has a major influence on efficiency of the waterjet unit at particular speeds. What's more, because waterjets do not have any underwater appendages increasing hull drag as speed increases, waterjets become more efficient as vessel speed increases - particularly when directly compared with conventional propeller propulsion systems.

HamiltonJet waterjets are designed to operate most efficiency in the 25-45 knot speed range, but still exhibit excellent efficiency above and below this range when sized and powered appropriately. In certain cases HamiltonJet waterjets have been found to be more efficient than larger sized units from other manufacturers, due largely to the specific design of that waterjet for the operating conditions of the vessel and the speed required.

## HJ Series Thrust Curve Envelopes

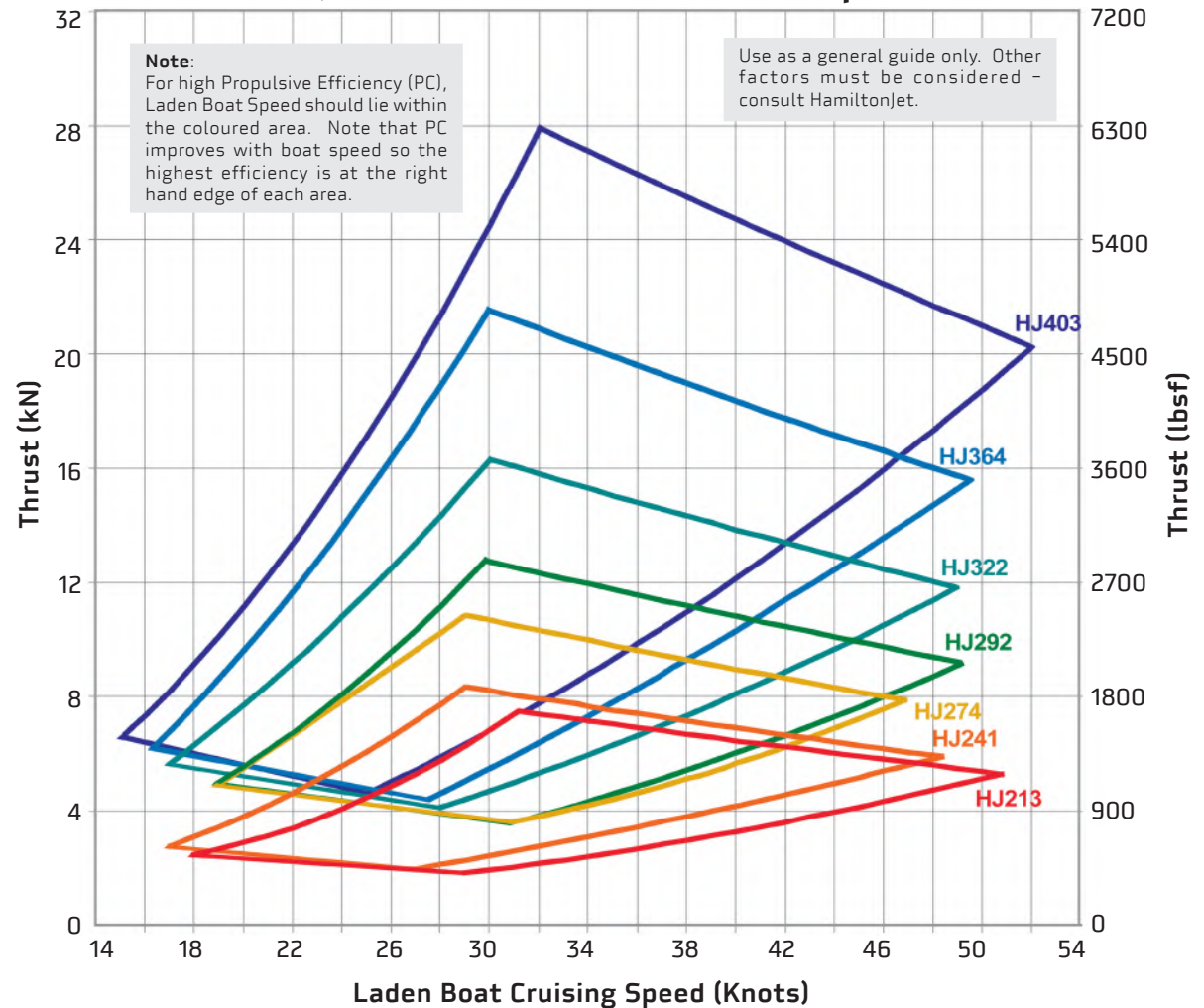

The HJ Series Thrust Curve Envelopes diagram (above) shows the optimal efficiency range for HamiltonJet HJ waterjets in high speed vessels. Knowing the **bare hull resistance** of your vessel at maximum laden boat speed, you can use the diagram to check that thrust required per waterjet is consistent with the approximate size waterjet calculated earlier.

# HamiltonJet Engine / Gearbox Selection

$$\text{Thrust Required per Waterjet} = \frac{\text{Bare Hull Resistance (no appendages)}}{\text{Number of Waterjets}}$$

In the case of our example boat, HamiltonJet’s hull resistance software calculates that a laden weight of 12,000kg requires 23kN (4,700lbf) of thrust to achieve a speed of 35 knots - which fits with the single HJ403 option. For twin waterjets this translates to 11.5kN (2,355lbf) per jet, which is borderline for the HJ292 option but fits well in the HJ322 optimum efficiency thrust curve envelopes.

To narrow down waterjet selection options further you can look at cost and space considerations of single versus twin drivelines, manoeuvring advantages of multiple waterjets, and the duties the boat will be performing (eg: towing, pushing etc). Also, consider the likelihood of the boat ending up heavier than predicted and the need for additional power and a larger water size to counter this.

## Engine & Gearbox Matching

Now use the Power / RPM Curves diagram (right) to match the power required per jet to the waterjet size options to determine suitable power / rpm specifications for engine and gearbox options.

## Engine Selection Notes:

In many cases HJ Series waterjets can be directly driven by a high speed diesel engine, without the need for a gearbox. However, some engine and vessel combinations may require the use of a gearbox to reduce RPM into the jet. This allows for a coarser pitch impeller match, which in turn improves the margins over cavitation, as well as improving the vessel’s acceleration and low speed bollard pull. A gearbox is also useful to allow running of the engine without driving the waterjet (neutral), for “Backflushing” (reverse rotation to clear debris), or for diverting engine power to another appliance.

Each HJ Series waterjet is fitted with an impeller specifically matched to the engine/gearbox combination used. Consult HamiltonJet for further information regarding engine matching.

## HJ Series Power / RPM Curves

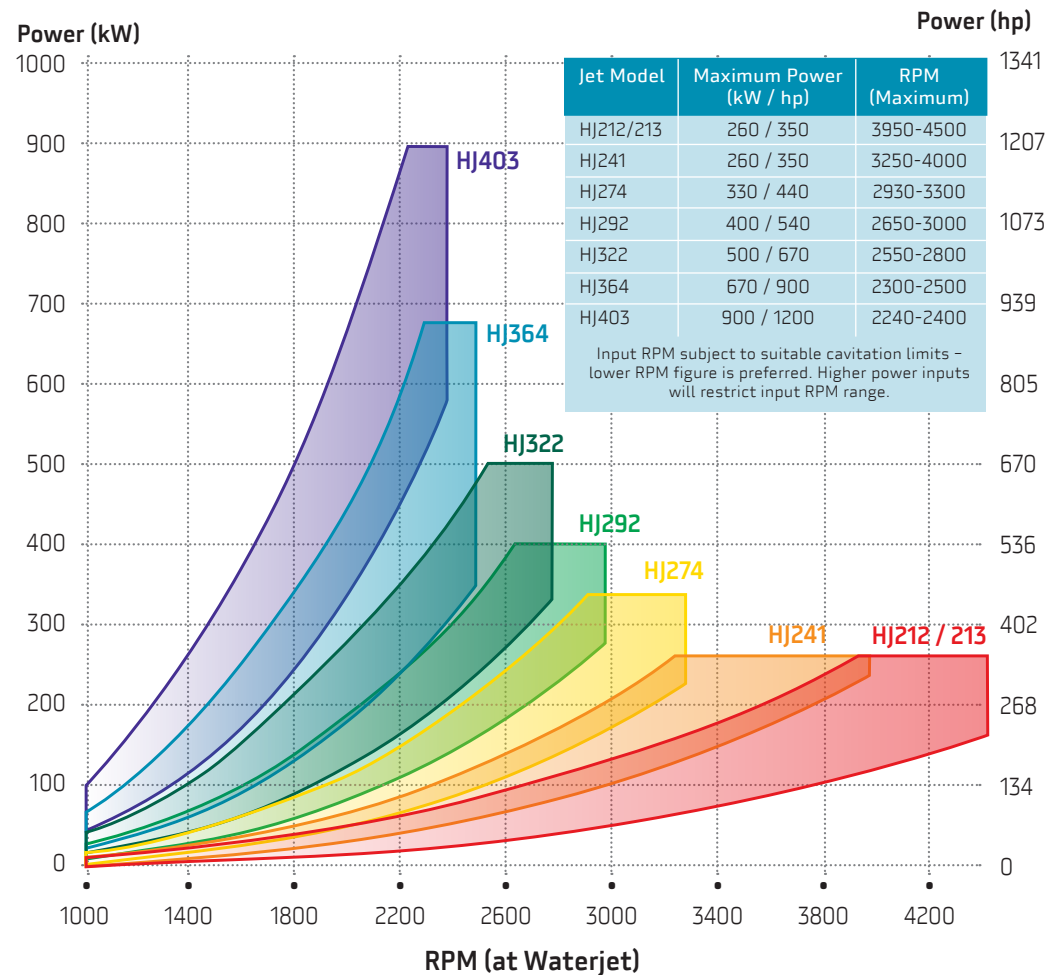

**Note:** Waterjet selection is determined by a range of hull and operational factors, most importantly vessel size and displacement (weight), and not necessarily by matching the above specifications to the desired engine power/RPM curve. In all cases you should consult HamiltonJet for assistance with waterjet selection.

# HJ Series Dimensions

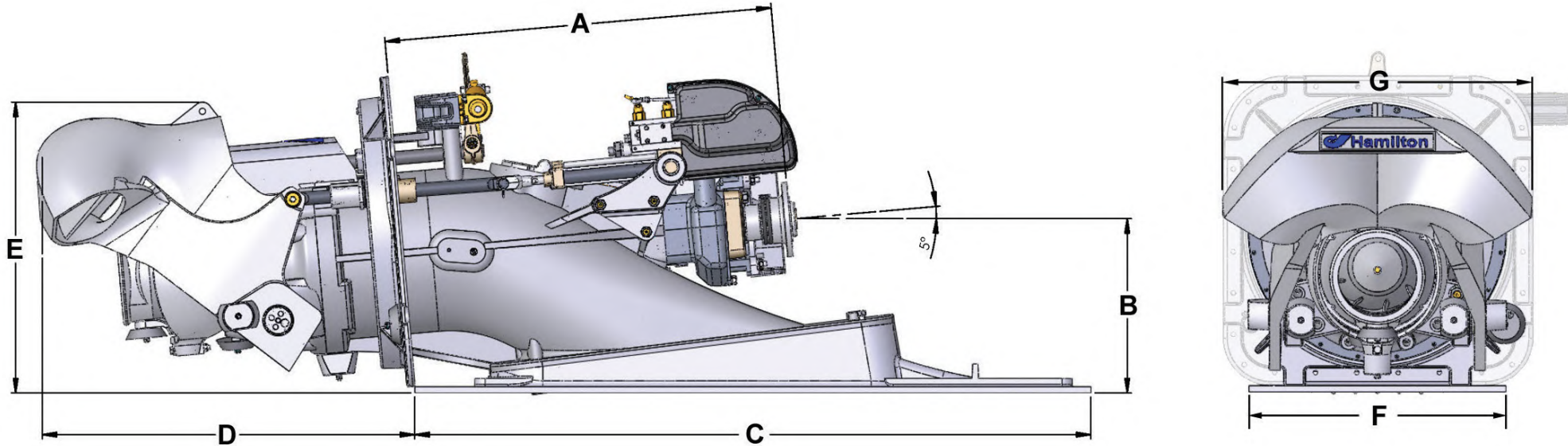

**STANDARD  
5° INTAKE  
OPTION**

Jet Model	A (mm)	B (mm)	C (mm)	D (mm)	E (mm)	F (mm)	G (mm)	Intake Block (kg / lbs)	Dry Weight (kg / lbs)	Entrained Water (kg / lbs)
HJ212	450.3 <sup>a</sup>	221.2	762	609	440	386	450	7 / 15.4	75 / 165	17 / 37
HJ213	413	249	762	609	420	386	450	7 / 15.4	84 / 185	17 / 37
HJ241	424	284	829	705	491	431	502	10 / 22	104 / 229	26 / 57
HJ274	570	302	1100	710	548	470	608	22 / 48.5	152 / 335	35 / 77
HJ292	681	330	1180	750	550	495	608	26.4 / 58	187 / 412	45 / 99
HJ322	866	371	1380	835	637	550	680	37 / 82	260 / 573	62 / 137
HJ364	937	420	1634	901	701	621	747	62 / 137	408 / 899	79 / 174
HJ403	1053	474	1723	1080	752	690	803	72 / 159	641 / 1407	110 / 243

NOTES: <sup>a</sup> - HJ212 "A" dimension is to the end of a splined shaft. May be close coupled.

Layout and dimensions shown are indicative only for initial design purposes, based on jets with standard 5° intake block which facilitates close direct drive coupling of the engine. Consult Hamiltonjet for more detailed information.



## HJ Series Dimensions

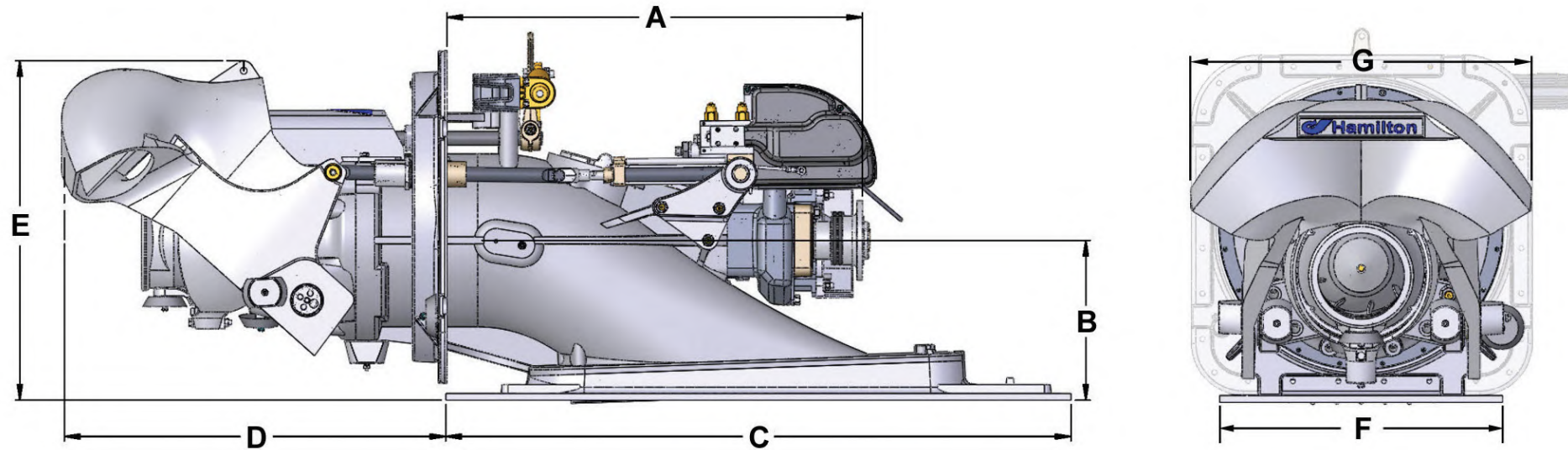

### OPTIONAL 0° INTAKE BLOCK

(Available with selected  
HJ waterjets only)

Jet Model	A (mm)	B (mm)	C (mm)	D (mm)	E (mm)	F (mm)	G (mm)	Intake Block (kg / lbs)	Dry Weight (kg / lbs)	Entrained Water (kg / lbs)
HJ274	570	270	1000	670	617	470	608	16 / 35	152 / 335	35 / 77
HJ292	681	290	1072	715	620	495	608	19 / 42	187 / 412	45 / 99
HJ322	866	320	1250	796	720	550	680	28 / 62	260 / 573	62 / 137
HJ364	937	360	1410	860	765	621	747	42 / 92.6	408 / 899	79 / 174
HJ403	1053	400	1466	1027	837	690	803	46 / 101	638 / 1407	110 / 243

NOTES: Layout and dimensions shown are indicative only for initial design purposes, based on jets with optional 0° intake block which positions the jet parallel to the hull bottom. Consult HamiltonJet for more detailed information.

# HJ Series Scope of Supply

## Standard Supply (All Waterjet Models)

- Waterjet Base Unit ("Wet-Run")
- Intake Block with Screen & Installation Kit (to suit aluminium, GRP, wood or steel hulls)
- Transom Seal Kit
- Coupling Flange (to suit specified driveline)
- Impeller to suit engine Power/RPM & Gearbox (if fitted)
- JHPU - Jet Mounted Hydraulic Power Unit (excluding HJ212)
- Astern Deflector
- Hydraulic Reverse Cylinder (excluding HJ212)
- Reverse Control Actuation Assembly (for H5RX, H5RC or HFRC - see page 10)
- Steering Assembly (JT Steering Nozzle, Shaft and Steering Tiller)
- Complete set of Anodes (excluding HJ212)
- Product Manuals (for Waterjet and Control System)

## Standard Supply (HJ292 - HJ403 only)

- Tie Rod Kit (for multi-jet installations)
- Helm Pump
- Steering Cylinder
- Steering Cylinder Mounting Bracket
- Steering Sender
- Steering Position Indicator

## Options in Lieu of Standard Supply

- Waterjet "Dry-Run" Base Unit
- Power Steering (HJ364 - HJ403 only)
- Boost Jet Option (no Reverse Assembly and/or Steering Assembly)
- blue ARROW® Electronic Control System (HJ292 - HJ403)
- MECS Electronic Control System (HJ364 - HJ403)

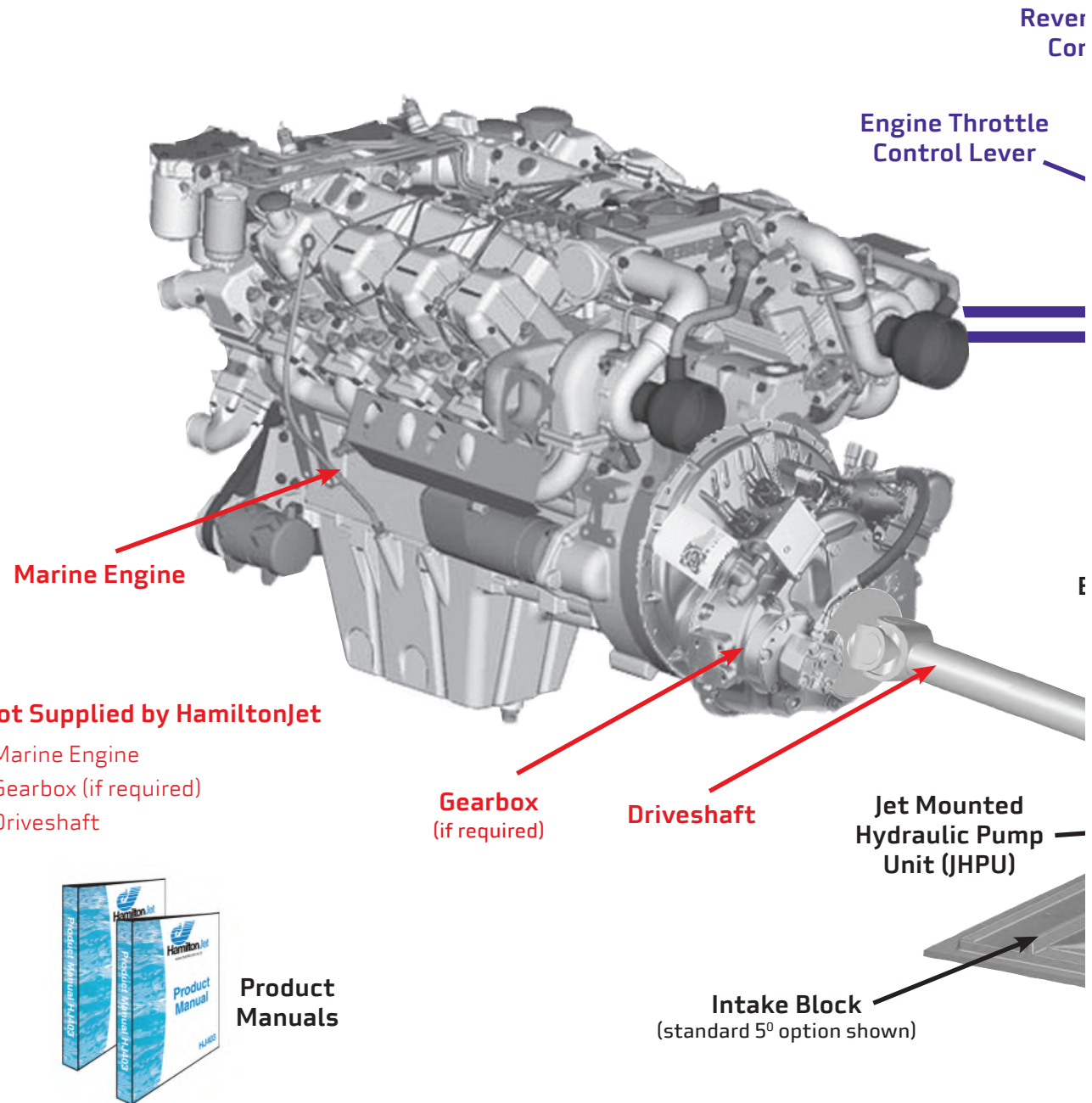

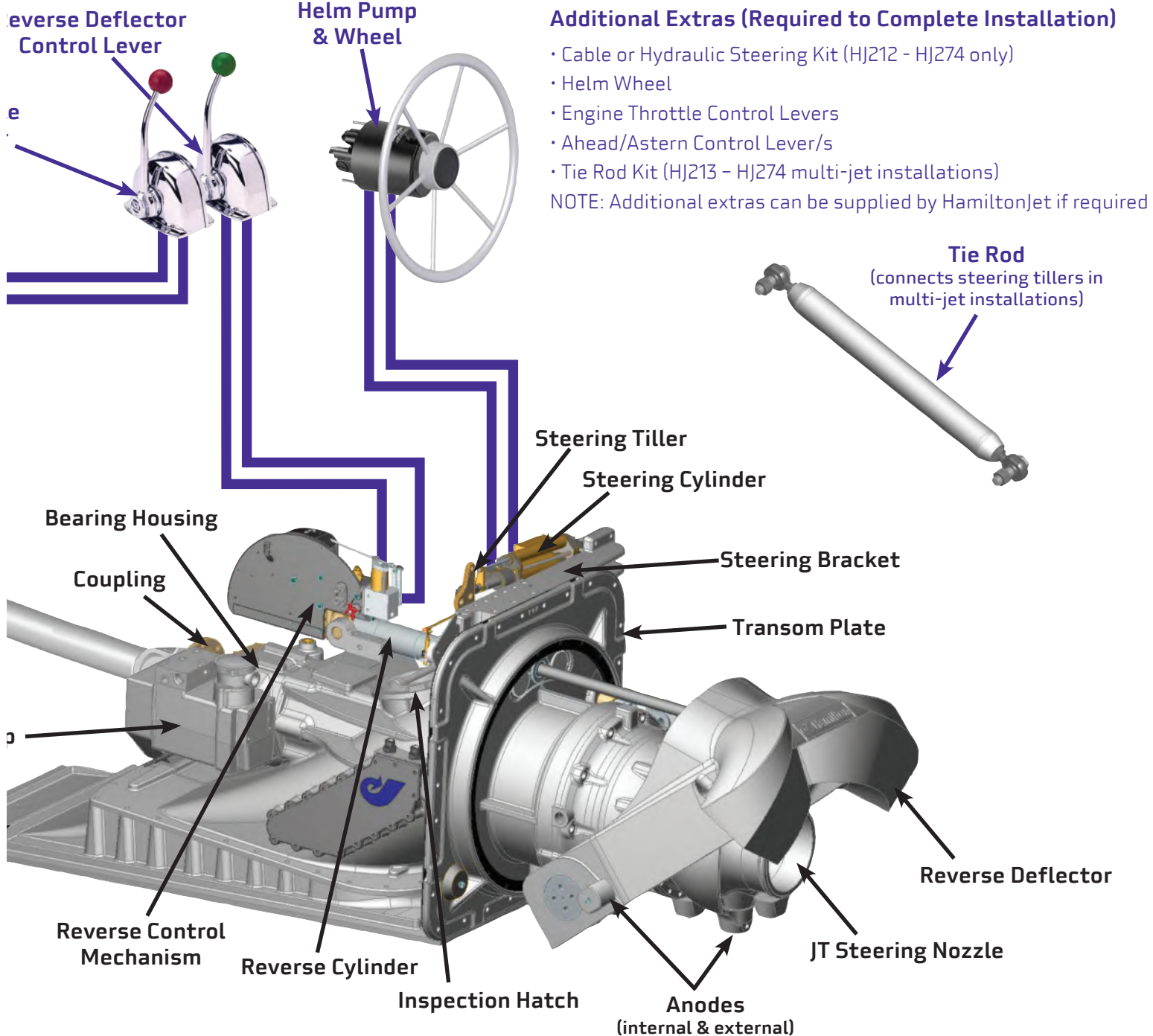

**Additional Extras (Not Necessarily Essential to Complete Installation)**

- Intake Screen Rake
- Inspection Hatch Extension
- Sand Trap
- Special Tools Kit
- Certification (ABS, Lloyds, BV, DNV etc)
- Reverse Senders
- Reverse Position Indicators

**Steering & Reverse Position Indicators**



**Screen Rake**  
(fits inside jet intake)



**Inspection Hatch Extension**



# HJ Series Installation

This section briefly explains how the jet is mounted in the hull. Detailed installation drawings are available on request and are also included in the Product Manual which comes with the jet.

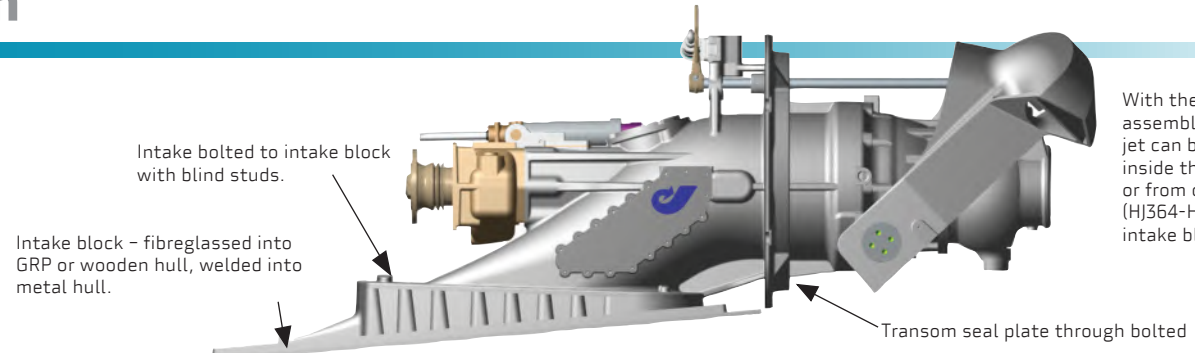

Typical Jet Installation (Aluminium Hull Arrangement Shown)

## Intake Block

The Intake Block forms an inlet in the hull bottom onto which the base of the jet intake fixes, allowing water to pass from under the hull up into the jet. All propulsive thrust loads are transferred into the hull via the Intake Block, not the transom.

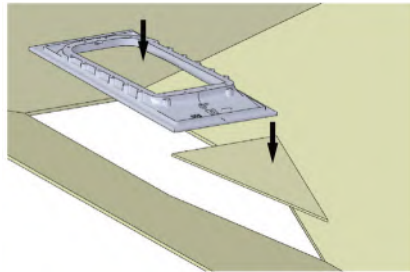

For jets on the hull centre line (single jet or centre jet of triple jet installation) the intake block when fitted forms a flat area aft in the hull bottom. A triangular shaped fairing has to be constructed by the boat builder to provide a smooth transition from the original vee hull form to the flat area of the intake block. The length of this fairing depends on the deadrise angle of the hull bottom.

For jets outside the hull centre line (twin jets or outside jets of triple jet installation) the Intake Block (and jet) always mount flush to the hull bottom at the deadrise angle.

**Note:** Minimum distance between waterjet centrelines will depend on hull deadrise angle. Consult your HamiltonJet Distributor for details.

For aluminium hulls a marine grade aluminium intake block is supplied, ready to weld into an opening cut into the hull bottom.

For wooden & GRP hulls the intake block supplied with the jet can be taped into the hull mould or fixed into an opening cut in a wooden or existing GRP hull for the boat builder to fibreglass over.

For steel hulls the aluminium intake must be electrically isolated from the steel hull to prevent corrosion. This is easily achieved using gaskets and bushes supplied by HamiltonJet. Contact HamiltonJet for more detailed instructions.

## Transom

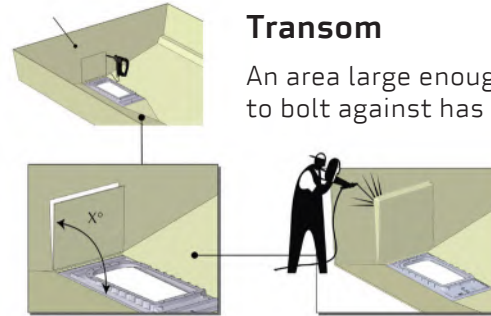

An area large enough for the jet transom seal plate to bolt against has to be carefully prepared at  $95^\circ \pm 1^\circ$  (or  $90^\circ \pm 1^\circ$  for  $0^\circ$  intake block option) to the intake block/hull bottom. A hole large enough for the aft of the jet to pass through is cut in this prepared transom area.

After removal of the reverse deflector, jet models HJ212-HJ322 are fitted from inside the hull and bolted onto the intake block. The transom plate is fitted over an O-Ring seal on the jet flange and bolted to the transom. Finally, the astern deflector is refitted. HJ364/HJ403 waterjets are fitted from outside the hull without removing the reverse deflector. A rubber seal is compressed between the jet's transom flange and a header ring, expanding the seal to press against the transom plate.

**Note:** All hardware for intake and transom mounting is supplied.

*HJ364 - HJ403 transom seal shown at right*

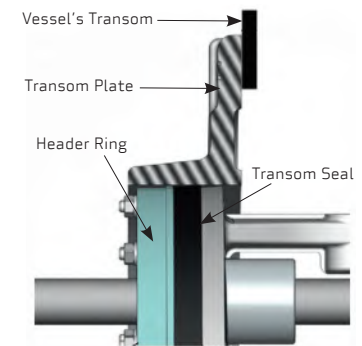

# HJ Series Driveline Requirements

## Requirements of the Driveline

- It must accommodate parallel and angular misalignment plus allow axial movement.
- It must transmit the torque input to the jet with an acceptable life expectancy. (It does not have to transmit thrust loads).
- Torsional flexibility may be required – especially with diesel engines.

## Engineering Checks Required

All driveline component suppliers (including engine and jet suppliers) must be consulted with full driveline details to ensure suitability and compatibility of components.

Checks Must Include...	Consult...
<ul style="list-style-type: none"> <li>• Critical Speed Check for whirling of jet main shaft</li> <li>• Critical Speed Check for whirling of drive shaft</li> <li>• Engine to Jet alignment</li> <li>• Torsional Vibration Analysis</li> </ul>	HamiltonJet Driveshaft supplier HamiltonJet Engine supplier (waterjet details necessary for this analysis are given in the relevant Waterjet Product Manual).

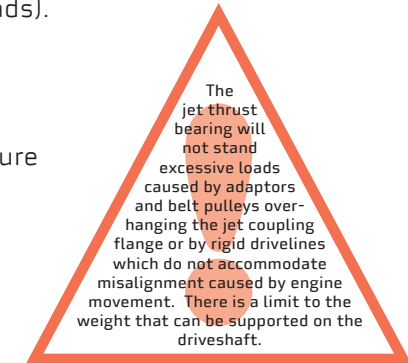

## Recommended Driveline Systems

Depending on the distance required between the engine and waterjet coupling flange, there are four recommended systems for coupling the engine to the jet.

### 1. Double Element Torsionally Flexible Drive Shaft

Use this type with support bearings such as the "Centaflex GZ" type illustrated. The engine is located in-line with the jet and can be flexibly mounted with this type of coupling.

Length is limited by the weight allowable at the jet coupling (refer Critical Speed Check).

Single element couplings are not suitable.

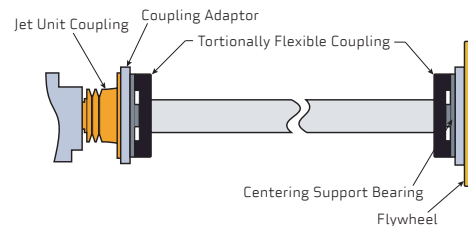

### 2. Double Universal Slip-Jointed Driveshaft

The usual method of coupling the engine to the waterjet is via a double universal slip-jointed driveshaft (Cardan Shaft). It bolts directly to the

jet coupling flange and to the engine flywheel (via an adaptor plate or torsionally flexible element).

Length is limited by the weight which can be allowed at the jet coupling (refer Critical Speed Check).

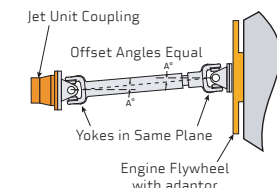

### 3. Double Constant Velocity Joint (Alternative)

A driveshaft with twin CV joints can be used with the same comments above being applicable.

### 4. Long Driveshaft

Where the driveshaft length, and thus weight, exceeds that allowable at the jet coupling, a fixed lineshaft supported in pedestal bearings can be used in conjunction with either universal driveshafts or torsionally flexible couplings.

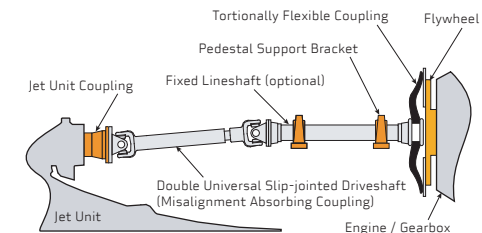

# HJ Series Control System Options

## Steering Control

The JT steering nozzle deflects water flow at the jet through an arc of  $\pm 27^\circ$  and the steering loads are relatively light. In most installations a manual hydraulic system is recommended, though for smaller jets a heavy duty rotary, rack & pinion or cable system may be sufficient. Larger waterjet models, particularly in multi-jet installations, may require a power-assisted hydraulic steering system. Between 1 and 2 turns of the helm wheel from lock to lock is recommended for most waterjet models. A greater number of turns will reduce steering sensitivity during slow speed manoeuvring. For HJ212 – HJ274 waterjet models the steering cylinder is mounted inboard on the transom, while for HJ292 – HJ403 waterjets the steering cylinder is mounted inboard on the waterjet.

## Hydraulic Steering

Steering operation is by a wheel directly driving a hydraulic pump mounted at the helm. Hydraulic line is required to interconnect the helm pump to a hydraulic cylinder mounted inboard on the jet. The hydraulic steering cylinder is connected to the steering tiller arm which in turn operates the steering deflector. A steering position indicator gauge and a jet mounted sender unit are supplied as standard for HJ292 – HJ403 waterjet models.

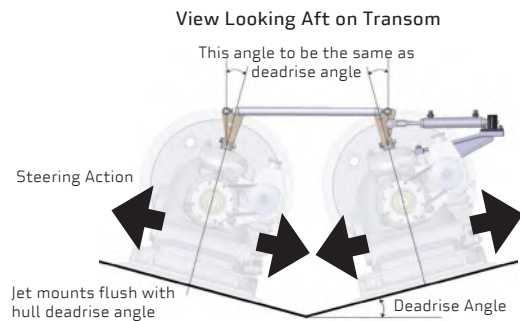
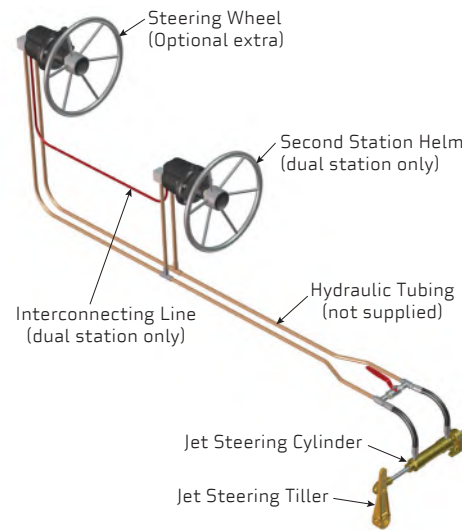

For multiple waterjets, gang control of steering is achieved by using swivel ended tie-rod(s) to interconnect the tiller arms. An adjustable length tie-rod is supplied (one with twin jets; two with triple jets) to facilitate accurate centering of the jets.

## Reverse Control

HamiltonJet supplies a hydraulic reverse control system as standard on all HJ Series waterjets (excluding the HJ212), with the type of control system determined by waterjet model...

- HSRX (Hydraulic Servo Reverse Control) for HJ213 – HJ274**  
 Provides exponential positioning control of the astern deflector. Exponential positioning control allows for fine control of the actuating cylinder where it is most needed – ie: around the “zero speed” position – and fast control where accurate positioning is not as critical – ie: when the deflector is fully raised or lowered.
- HSRC (Hamilton Synchronised Reverse Control) for HJ292 – HJ322**  
 Provides “follow up” positioning control of the astern deflector. The deflector’s movement is synchronised with the control lever movement – the control lever position indicates deflector position and a separate position indicator is not necessary.
- HFRC (Hamilton Follow-up Reverse Control) for HJ364 – HJ403**  
 Provides unsynchronised “follow-up” positioning control of the astern deflector. This means the control lever can be moved quickly and the deflector will follow at its own speed to find the required position. The operator can pre-set reverse lever position prior to engine start, then at start up the deflector will immediately move to the correct position. What’s more, unlike synchronised controls the system cannot be strained or forced by the operator.

## Electronic Control Systems

- blue ARROW® Control System for HJ292 – HJ403**  
 A complete waterjet and controls package, incorporating single or twin waterjet units, jet control interfaces, engine throttle and gearbox interfaces, together with helm station devices. blue ARROW® features multiple levels of redundancy, independent smart backup and comprehensive diagnostics, making it very safe and reliable.
- MECS (Modular Electronic Control System) for HJ364 – HJ403**  
 A high level certifiable electronic control system for operating up to 5 waterjets. It is very reliable and flexible for number of waterjets and helm stations. Offers additional interfaces such as Dynamic Positioning and Voyage Data Recording.

# HJ Series Material Specifications

Materials used in the manufacture of HamiltonJet waterjets are selected based on the particular qualities they provide in terms of weight, durability and strength, corrosion resistance, ease of manufacture and handling, and cost reduction.

The main casings of the waterjet is cast from LM6 Marine Grade Aluminium, which is very strong and durable for its weight and can be easily and accurately cast and machined.

All parts moving in the water flow and subject to higher risk of wear from water-bourne particulates are manufactured from high quality stainless steel. This includes the mainshaft, impeller, wear ring and bearing sleeve.

The wear ring is electrically isolated from the aluminium casings through the use of Micarta and rubber insulators to ensure no corrosion occurs in this area through electrolysis. Corrosion prevention is also supported by an extensive network of sacrificial anodes made from zinc and in some cases aluminium.

	<b>HJ212</b>	<b>HJ213</b>	<b>HJ241</b>	<b>HJ274</b>	<b>HJ292</b>	<b>HJ322</b>	<b>HJ364</b>	<b>HJ403</b>
Impeller Size (mm/in)	215 / 8.5	215 / 8.5	240 / 9.49	270 / 10.5	290 / 11.4	320 / 12.6	360 / 14.17	400 / 15.75
No. of Impeller Options	7	14	12	20	15	17	18	15
Impeller Range (kW)	1.8-4.1	1.8-5	3.7-7.5	6.5-13	10-21.5	15-36	21-57	42-90
Impeller Rotation	Left-hand only (anti-clockwise looking at engine flywheel)							
Steering	Steerable JT Type Nozzle with Inboard Tiller							
Ahead/Astern	Split Duct Type Deflector							
Thrust Bearing	Angular Contact Ball Type						Spherical Roller Type	
Tail Bearing	Water Lubricated Cutless Rubber Type							
Shaft Seal	Face Type Mechanical Seal							
Transom Seal	O-Ring Type						Compressed Rubber Type	
Intake Screen	Steel Bars	Flush-Mounted Aluminium Bars						
Inspection Hatch	Inboard							
Water Offtake(s)	3/4" BSP Inboard			1-1/4" BSP Outboard			1" BSP Outboard	
Paint Finish	Gloss			Anti-foul Undercoat or Gloss				Anti-foul
Corrosion Protection	None	Cathodic with internal and external anodes						
Mainshaft Material	431 SS	SAF 2205 Stainless Steel (UNS S 31803 to ASTM A276)						
Casing Material	Cast LM6 Marine Grade Aluminium Alloy to BSI 490-1970							
Impeller Material	Cast CF8M Stainless Steel to ASTM A743-80a							
Hydraulic Steering	Optional Accessory				Manual Hydraulic		Power	
Ahead/Astern Control	Manual	HSRX			HSRC		HFRC	
Electronic Controls	None				blue ARROW		blue ARROW or MECS	
Mounting	Conventional Inboard Mount on Intake Block							
Transom Angle at Jet	95° ± 2°			95° ± 1° for Standard 5° Intake Block 90° ± 1° for Optional 0° Intake Block				
Intake Block	Available to suit Aluminium, GRP and Steel Hulls							
Coupling Flange	To suit ELBE, GWB, Hardy Spicer or AquaDrive (Consult HamiltonJet for option details)							
Fastening Kit	Complete kit of nuts, bolts, washers etc in type 316 Stainless Steel and Silicon Sealant							
Manuals	Product Manual only				Product Manual + Control System Manual			





WORLD HEADQUARTERS

**HamiltonJet Global**

PO Box 709  
Christchurch  
New Zealand  
Phone: +64 3 962 0530  
Fax: +64 3 962 0534  
Email: [marketing@hamjet.co.nz](mailto:marketing@hamjet.co.nz)  
[www.hamiltonjet.co.nz](http://www.hamiltonjet.co.nz)

REGIONAL OFFICES

**HamiltonJet Americas**

14680 NE North Woodinville Way  
Suite 100  
Woodinville WA 98072  
United States of America  
Phone: +1 425 527 3000  
Toll Free: 800 423 3509  
Fax: +1 425 527 9188  
Email: [marketing@hamiltonjet.com](mailto:marketing@hamiltonjet.com)  
[www.hamiltonjet.com](http://www.hamiltonjet.com)

**HamiltonJet Europe**

Unit 26, The Birches Industrial Estate  
East Grinstead  
West Sussex RH19 1XZ  
United Kingdom  
Phone: +44 1342 313 437  
Fax: +44 1342 313 438  
Email: [marketing@hamjetuk.com](mailto:marketing@hamjetuk.com)

**HamiltonJet Asia**

Phone: +65 6567 2202  
Fax: +65 6567 4788  
Email: [hamiltonjet.asia@hamjet.co.nz](mailto:hamiltonjet.asia@hamjet.co.nz)

Your local HamiltonJet Distributor is...

Cover: blue ARROW Rescue, Christchurch, New Zealand. Twin HamiltonJet HJ322 waterjets.



**HamiltonJet**