

T R I M T A B S





INDEX

Company Profile	3
Introduction	4-5
▼ TRIM TAB SYSTEMS FOR BOATS WITH SPEED LOWER THAN 40 KNOTS	
Main Features of Stainless Steel Trim Tab Systems	6-7
Working Principle	8-9
Stainless Steel Trim Tab System Selection	10-11
Trim Tab Systems Composition Series MY3000	12-15
Trim Tab Systems Composition Series MY5000	16-19
Trim Tab Systems Composition Series MY4000	20-25
▼ TRIM TAB SYSTEMS FOR BOATS WITH SPEED OVER 40 KNOTS	
Main Features of Aluminum Trim Tab Systems	26-27
Aluminum Trim Tab Systems Selection	28
Aluminum Trim Tab Systems Composition	29
Trim Tab System Series MY10001	30
Trim Tab System Series MYOFF2	31
Trim Tab System Series MYOFF6	32-33
Trim Tab System Series MY40001	34-35
Accessories	36
Warranty Conditions and International Distributors	back cover

NOTE: Twin Disc SRL declines any liability for possible mistakes in this catalogue due to printing errors and reserves the right to make any modification that is considered to be necessary or useful for its products. Publishing rights, trade marks, part numbers and photographs present on this catalogue are Twin Disc SRL property or it has the necessary authorization to use them. So, all rights are reserved and any reproduction, even partial, is forbidden. Our products cannot be installed on racing boats without our previous authorization.

Production plants in Limite sull'Arno



From concept to production:

Throughout our nearly sixty years of experience, BCS has become a leading company in the production and worldwide distribution of high quality marine equipment. The acquisition by Twin Disc, Inc. – leader in several different areas such as marine and industrial, heavy duty transmissions and the oil extraction industry – has consolidated its position on the market as part of a multinational group.

Twin Disc SRL combines BCS, BCS Service, Twin Disc Technodrive and Twin Disc Propulsion. Twin Disc SRL is also supported by a sister-company, Rolla SP Propellers.

Global 'Package'

Twin Disc SRL offers to boat builders and design engineers a complete "package" of products, from propulsion systems to gearboxes and transmissions up to control and steering systems, together with customized solutions and efficient technical support. Also global customer service for the development and realization of the whole kinematics system.

A dynamic team of engineers, technicians and professional people is devoted to support the customer in any step: from concept of the project to the planning, through prototype development and design definition, up to bench and field testing, production, assembly, installation and service also on board.

prototype development, care for design, field testing, product definition

Twin Disc SRL works alongside the customer every day. We have established a unique worldwide system dedicated to the marine industry based on our ability to acknowledge and anticipate market requests, the certified reliability of our products, skilled service and the continuous research of technological innovation.

The production plant of Limite sull' Arno produces equipment covering several application fields: Hydraulic and electronic steering systems, complete shaft lines for boats up to 40 meters, trim tab systems in stainless steel or aluminum, electric and hydraulic bow and stern thrusters, electrohydraulic gangways and side ladders for large applications, as well as a large variety of stainless steel hydraulic actuators and multi-function electrohydraulic power units.



INTRODUCTION



Fig. 1



Fig. 2

Trim tab systems have become a nearly 'standard' system on every boat. They are crucial to a boat's performance, helping to make the control easier and safer.

A tab is actually a mobile extension of the hull connected to the lower end of the transom on both sides. This improves boat balance in many different situations, due to this increased surface. Therefore, the trim tabs must be regarded as a means to correct the boat balance when needed.

Trim tabs' efficacy is based on the principle that the water flowing on the tab surface causes the boat's stern to be "raised" as much as the tab is lowered. In many situations it is possible to take advantage of this principle:

- Getting on plane from a stand still: when the boat is at a stand still, the stern tends to drag down into the water and make it difficult for the boat to take off and get on plane (Fig. 1). When the tabs are deflected downward, the water force creates an upward pressure and helps the stern to raise, reducing the hull resistance (Fig. 2). Therefore, the larger the tab surface and higher the deflection angle and boat speed, the greater the lift will be and the faster the boat will get on plane.
- The trim tab system improves the propulsion system performance: When the stern is dragged too far down into the water, the propeller is actually too low and at an ineffective angle (Fig. 3). For the best performance, the propeller should always be as parallel as possible to the water flow (Fig. 4).

Fig. 3



Fig. 4



Fig. 5



Fig. 6

- Safety: better boat balance improves the driver's visibility by enlarging his field of vision.
- Lateral control: Because trim tabs are mounted on both sides of the boat's stern and can be operated independently, it is possible to control any weight shift that can result in the vessel's listing. By deflecting one tab more than the other, it is actually possible to control this side-to-side movement (Fig. 5) and take the lower side to the right level (Fig. 6). Such a function is crucial, especially since smaller boats are more affected by a weight shift (or when crew members or guests are not well distributed on board).
- Plane control: Small adjustments of the trim tabs while cruising assist the boat to stay on plane while running at any speed. This also reduces fuel consumption.
- Smoother and drier rides: Trim tabs assist the boat in keeping a better position more parallel to the water surface, and allow the bow to cut through the waves and reduce the pounding.

BENEFITS:

1) Performance improvement

- Stern lifting and better balance
- Faster getting on plane
- Better propeller efficiency
- Listing correction
- Decrease of yawing and wandering

2) Safety improvement

- Better and greater visibility
- Better maneuverability at low cruising speed

3) Efficiency improvement

- Better engine performance
- Reduced fuel consumption
- Staying on plane even at slower cruising speed

MAIN FEATURES OF STAINLESS STEEL TRIM TAB SYSTEMS

Twin Disc stainless steel trim tab systems are available in a large variety of dimensions and can be combined with four different hydraulic kits, satisfying many different requirements and covering a wide application field.

A range of accessories complete the system and make their use easier and more efficient. For a detailed description, see page 36.

HINGE
It is the fixed part of the tab, which connects it to the transom. On all models the hinge already has holes for the connection to the hull.

3

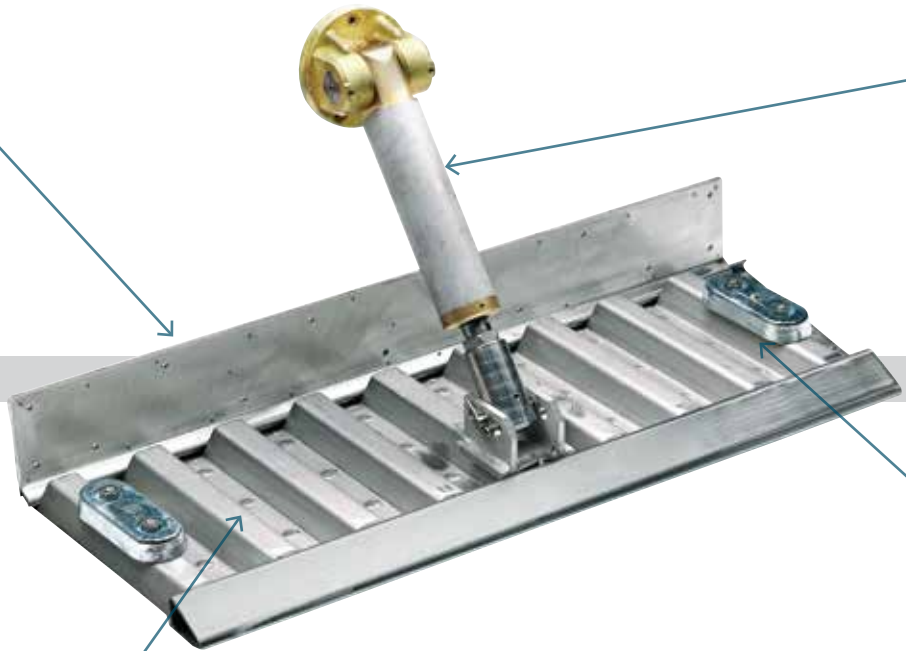

TAB
All tabs are stainless steel for the highest corrosion resistance. Series MY3000, MY4000 and MY5000 are available in two tab types: the **simple** tab is made out of a **single** plate and is suitable for application on smaller boats or with lower loads; the **reinforced** tab includes a reinforced plate which makes it stronger to better bear higher forces on the larger applications. Tabs of MY3000 series are provided with welded connection cylinder.

2

HYDRAULIC CYLINDER

The hydraulic cylinder is the real “power source” of the trim tab system. It is connected to the tab and permits its deflection. The cylinder itself determines the different models and system configurations. Two different types of cylinders are available:

- **Series MY3000 (single acting)** pushes only and the piston return is achieved by an internal spring, aided by the water pressure
- **Series MY4000 and MY5000 (double acting)** piston is hydraulically pushed out and pulled back again for a more powerful action

Neither type of cylinders have external hoses as the oil flows internally through the cylinder's base, which is directly fixed to the transom. This feature guarantees a longer life and better performance, as external hoses are exposed to sun, water and the impact with foreign bodies. The piston rod is stainless steel.

1

ZINC ANODE

The zinc anode has the function to protect the tabs against the galvanic currents that normally develop between metals of different nature. It is actually the so-called “sacrificial anode” and it provides an electro-chemical protection.

The principle consists in mounting these items made out of a less noble metal than the one to protect, so as the corrosive action just applies to the anode, allowing the tab to remain undamaged. It is normally placed in the central part for the smallest tabs or in a doubled quantity on both sides of the tab for the largest ones.

4

WORKING PRINCIPLE

By pushing one of the buttons on the control panel, the electrohydraulic power unit receives an electric impulse which starts the electric motor. In turn, the latter makes the hydraulic pump start; this sends an oil flow towards the side of the hydraulic cylinder corresponding to the desired movement (up or down).

Each button controls the movement of one tab. The trim tab system is completed with the installation of a trim tab angle indicator set, which helps to keep the tab position and its adjustments under control.

The System

A stainless steel cable with a protection hose is fixed to the lower end of the cylinder on each tab and, passing through the hull, it connects to a box containing the transmitter. The transmitter records every cylinder movement and sends it to the angle indicator placed on the bridge dashboard, which shows the angle on a scale from -2° and $+12^{\circ}$.

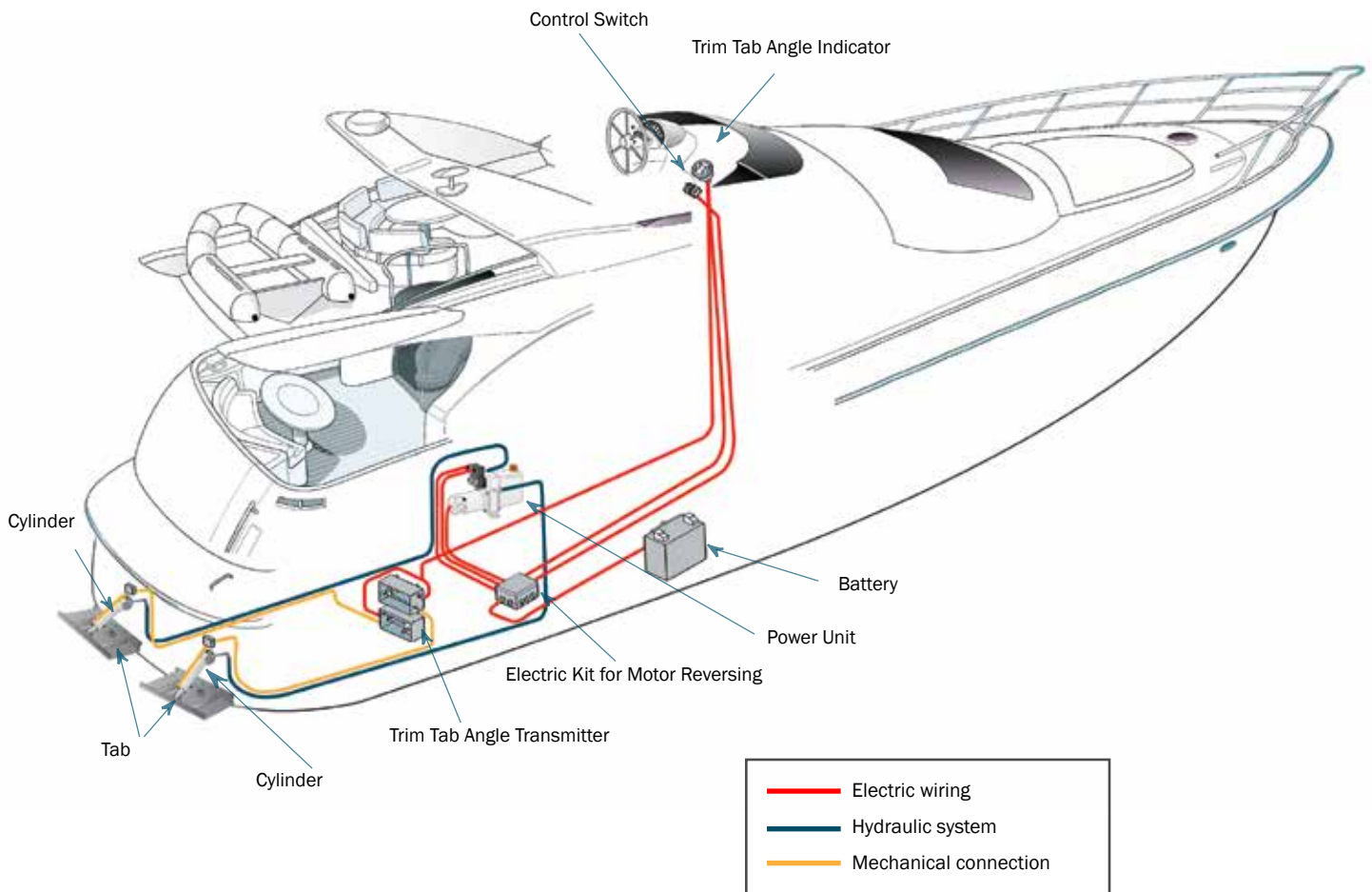

ELECTRONIC TRIM TAB CONTROL PANEL

The new electronic trim tab control panel includes a compact design and LED technology with adjustable intensity. The panel uses the built-in position sensors inside the cylinders for trim tab control and position detection.

The panel is provided with an “auto-retract” system that guarantees an automatic retraction of the tabs when turning off the engine. This protects the piston rod from both corrosion and encrustments that could damage the seals.

The panel’s reduced dimensions optimize space on the dashboard and facilitate a possible multi-station mounting. Waterproof and with protection type IP65, it is not susceptible to corrosion. Supplied with harness wires in several lengths with fast-lock connectors and without screws, it allows for fast and easy installation.

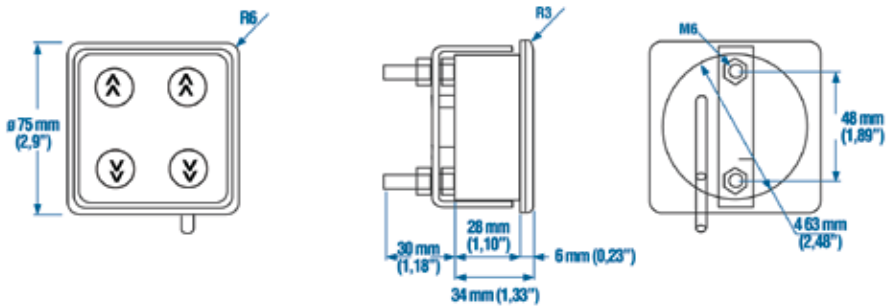

Code: IT30036

WORKING PRINCIPLE SCHEME

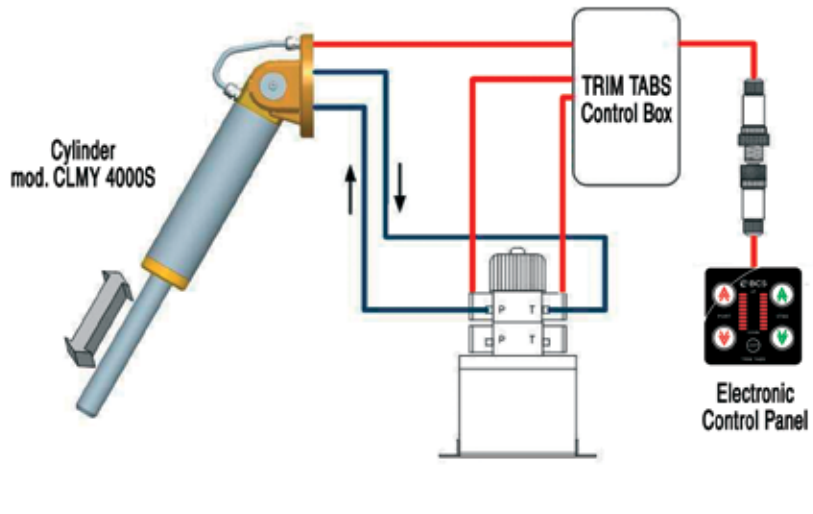



STAINLESS STEEL TRIM TAB SYSTEMS SELECTION

For the most suitable model, it is important to consider factors which have the greatest influence on system performance such as boat dimensions and displacement, as well as maximum speed.

To select the right system, we have created a simple Order Guide. Starting with the boat type (planing or displacement) and length, select the maximum speed (with speed lower than 40 knots) and the full-load displacement to obtain the hydraulic kit model and the tab dimensions suggested for a specific application.

The hydraulic kits series MY5000 represent an alternative to the kits mod. MY3000/4 and mod. MY4000/2. The model MY50003/2 is the ideal solution to replace the MY3000/4 with a double-acting cylinder, providing a bigger thrust by installing only one cylinder on each tab. The kit mod. MY50004/2 is instead an alternative for kit mod. MY4000/2 in case you need to mount a double-acting cylinder with reduced dimensions. To receive a complete system, simply order the codes of the tab kit and the hydraulic kit shown on the table below.

HOW TO ORDER

Boat type	Boat Length LOA		Displacement	Speed	Suggested Hydraulic Kit		
					Model		
 Planing hull	< 12,80 mt / 42'	7,50-9,00 mt • 25'-30'	< 17 Tons	< 40 Knots	single acting	MY3000/2-12 MY3000/2-24	
		9,00 -11,50 mt • 30'-38'					
		11,50-12,80 mt • 38'-42'					
	12,80-18,30 mt / 42'-60'	12,80-14,00 mt • 42'-46'	< 35 Tons	< 40 Knots	single acting	MY3000/4-12 MY3000/4-24	
		14,00 -15,20 mt • 46'-50'					
		15,20 -16,45 mt • 50'-54'			double acting	MY50003/2-12 MY50003/2-24	
		16,45-18,30 mt • 54'- 60'					
	18,30-22 mt / 60'-70'	18,30-18,90 mt • 60-62'	< 55 Tons	<40 Knots	double acting	MY4000/2-12 MY4000/2-24 MY4000S/2-24 MY50004/2-12 MY50004/2-24	
		18,90 -19,50 mt • 62'-64'					
		19,50 -20,00 mt • 64'-66'					
		20,00-21,00 mt • 66'-68'					
		21,00-22,00 mt • 68'-70'					
	22-39,60 mt / 70'-130'	22,00 -23,0 mt • 70'-75'	<130 Tons	<35 Knots	double acting	MY4000/4-12 MY4000/4-24 MY4000S/4-24 MY50004/4-12 MY50004/4-24	
		23,00 -24,50 mt • 75'-80'					
		24,50-27,00 mt • 80'-88'					
		27,00-28,50 mt • 88'-94'					
28,50-30,50 mt • 94'-100'							
30,50-33,50 mt • 100'-110'							
33,50-36,60 mt • 110'-120'							
36,60-39,60 mt • 120'-130'							
 Semi- Displacement hull	<12,80 mt / 42'	Up to 11,50 mt • Up to 38'	15 Tons	<18 Knots	double acting	MY4000/2-12 MY4000/2-24 MY4000S/4-24 MY50004/2-12 MY50004/2-24	
		11,50-12,80 mt • 38'-42'	37 Tons				
	12,80-18,30 mt / 42'-60'	12,80-15,20 mt • 42'- 50'	55 Tons				
		15,20-18,30 mt • 50'-60'					
		18,30-19,20 mt • 60'-63'					
	18,30-22 mt / 60'-70'	19,20-20,50 mt • 63'-67'	<130 Tons			double acting	MY4000/4-12 MY4000/4-24 MY4000S/4-24 MY50004/4-12 MY50004/4-24
		20,50-22,00 mt • 67'-70'					
	22-39,60 mt / 70'-130'	22,00-24,0 mt • 70'-78'					
		24,00-26,00 mt • 78'-86'					
		26,00-28,50 mt • 86'-94'					
		28,50-30,50 mt • 94'-100'					
		30,50-33,50 mt • 100'-110'					
33,50-36,60 mt • 110'-120'							
36,60-39,60 mt • 120'-130'							

The table shall be intended as a general reference only.

Example: For a boat with the following characteristics, a hydraulic kit mod. MY3000/4 at 24 V is suggested:

- length 15 mt
- weight < 35 Ton.
- maximum speed < 40 knots
- voltage 24 V

Assuming that a tab mod. MY3R-7430 of 740x300mm fits the transom of this boat, the codes to order are 25090 + 25099 + 26523.

It is important to keep in mind some crucial points such as:

- the LARGER the boat dimensions and weight are, the GREATER lift will be required
- smaller fast boats normally require smaller tabs, while larger and slower boats normally require larger tabs
- high speed boats (maximum speed over 40 knots) usually require tabs with a limited width, but with a longer length (see page 28).

Considering that the wider the tab surface is, the greater lift and the better system performance will be obtained, a rule of thumb suggests choosing the largest tab dimension that comfortably fits the length and shape of the transom, unless there is any special need.

For questions about a specific application, please consult the Twin Disc Technical Dept. or one of our authorized dealers.

		Tab Kits		Accessories	
	Code	Model	Code	Control Panel	Angle Indicator Kit
	IT25095 IT25096	MY3S-3030	IT25083	code: IT24766 For more details see the accessories section on pages 36-37. The cylinder with built-in sensor mod. CLMY 4000S should be combined only with the electronic control panel code: IT30036	Choose the model and the code of the trim tab angle indicator according to the selections table on page 36
		MY3S-5030	IT25084		
		MY3S-6030	IT25085		
	IT25098 IT25099	MY3/5S-7030	IT25088		
		MY3/5R-7430	IT25090		
	IT27467 IT26523	MY3/5R-8045	IT25093		
		MY3/5R-10035	IT25094		
	IT25128 IT25131 IT27474 IT27471 IT28544	MY4/5S-8040	IT25102		
		MY4/5S-9040	IT25104		
		MY4/5R-8045	IT25163		
		MY4/5R-9045	IT25111		
		MY4/5R-10045	IT25110		
	IT25132 IT25133 IT27478 IT28543 IT27472	MY4R-10045	IT25110		
		MY4R-15045	IT25160		
		MY4R-20045	IT25125		
		MY4R-20050	IT25127		
		MY4R-20050	IT25127		
		MY4R-20050	IT25127		
		MY4R-20050	IT25127		
	IT25128 IT25131 IT27478 IT27471 IT28544	MY4/5S-6035	IT25101		
		MY4/5S-8040	IT25102		
		MY4/5S-9040	IT25104		
		MY4/5R-10040	IT25115		
	IT25132 IT25133 IT27478 IT28543 IT27472	MY4R-10040	IT25115		
		MY4R-10040	IT25115		
		MY4R-12040	IT25119		
		MY4R-15050	IT25123		
		MY4R-20050	IT25127		
		MY4R-20050	IT25127		
		MY4R-20050	IT25127		
		MY4R-20050	IT25127		
		MY4R-20050	IT25127		

TRIM TAB SYSTEMS COMPOSITION SERIES MY3000

Tab Kits

Model	Code	Description
MY3S - 3030	IT25083	Complete tabs kit simple type 11,81"x11,81"
MY3S - 5030	IT25084	Complete tabs kit simple type 19,62"x11,81"
MY3S - 6030	IT25085	Complete tabs kit simple type 23,62"x11,81"
MY3/5S - 7030	IT25088	Complete tabs kit simple type 27,56"x11,81"
MY3/5R - 7430	IT25090	Complete tabs kit reinforced type 29,13"x11,81"
MY3/5R - 8045	IT25093	Complete tabs kit reinforced type 31,40"x17,66"
MY3/5R - 10035	IT25094	Complete tabs kit reinforced type 39,37"x13,78"

Simple Tab Kit Composition

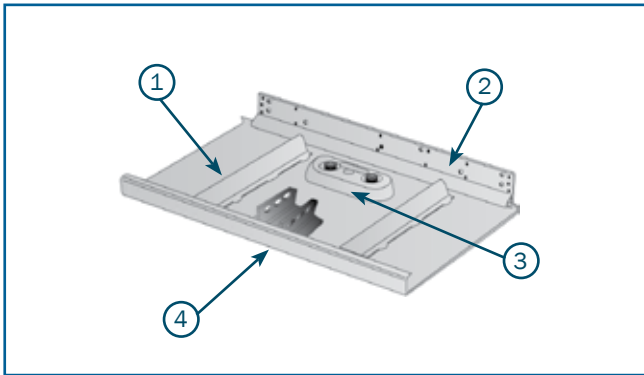

Position	Description	Qty.
1	Simple Tab	2
2	Hinge	2
3	Zinc anode	2
4	Cylinder connection	2

Reinforced Tab Kit Composition

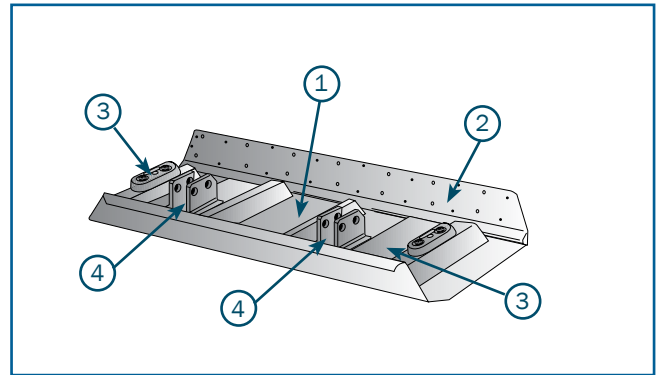

Position	Description	Qty.
1	Reinforced Tab	2
2	Hinge	2
3	Zinc anode	4
4	Cylinder connection	4

Note: For dimensions and main features see pages 16-17.

Hydraulic Kits

Model	Code	Description
MY 3000/2 - 12	IT25095	Hydraulic kit with single acting cylinder with one cylinder each tab - 12 V
MY 3000/2 - 24	IT25096	Hydraulic kit with single acting cylinder with one cylinder each tab - 24 V
MY 3000/4 - 12	IT25098	Hydraulic kit with single acting cylinder with two cylinders each tab - 12 V
MY 3000/4 - 24	IT25099	Hydraulic kit with single acting cylinder with two cylinders each tab - 24 V

Optional Accessories

Model	Code	Description
PANEL	IT24766	Control panel
See pages 36-37 to choose type and purchase code		Trim tab angle indicator kit

Hydraulic Kit Composition mod. MY3000/2

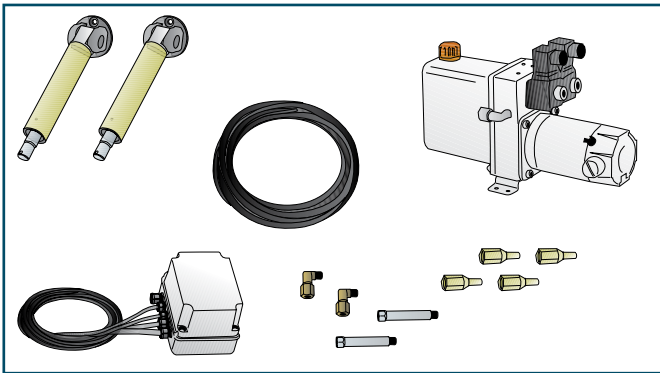

Description	Qty.
Single acting cylinders provided with pins for connection	2
Power unit mod. C097A	1
Electric kit for motor reversing mod. KITIM 201 or 202	1
Flexible hose type R7 3/16"	15 mt - 49 ft
Elbow fittings G1/8" - o.d. 6 mm	2
Reusable straight fittings hose type R7 3/16" - connector o.d. 6 mm	4
Through-hole G1/8" L=3,02 in.	2

Hydraulic Kit Composition mod. MY3000/4

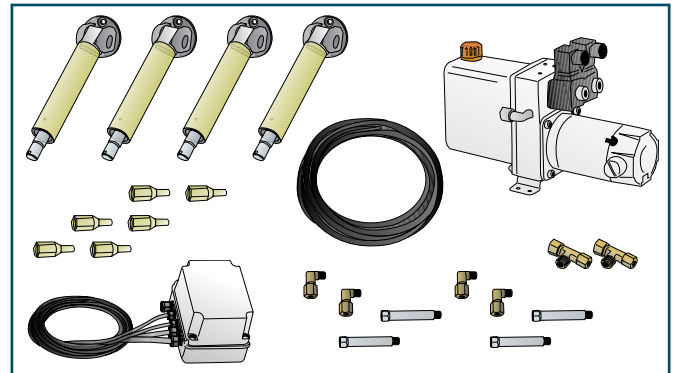

Description	Qty.
Single acting cylinders provided with pins for connection	4
Power unit mod. C099	1
Electric kit for motor reversing mod. KITIM 201 or 202	1
Flexible hose type R7 3/16"	15 mt - 49 ft
Elbow fittings G1/8" - o.d. 6 mm	4
Tee fittings G1/8" - o.d. 6 mm	2
Reusable straight fittings hose type R7 3/16" - connector o.d. 6 mm	8
Through-hole G1/8" L=3,02 in.	4

Note: For dimensions and main features see pages 16-17.

MAIN FEATURES OF SERIES MY3000 TRIM TAB SYSTEM COMPONENTS

Trim Tab Dimensions

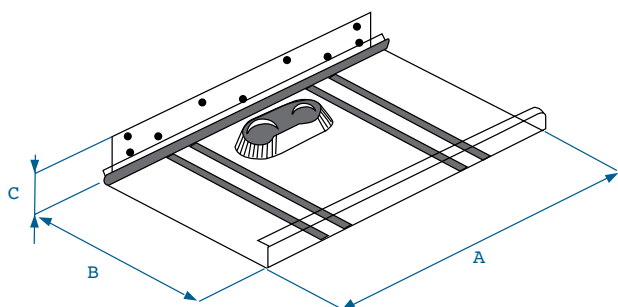

Dimensions			
Model	A	B	C
MY3S-3030	300 mm-11,81 in	300 mm-11,81 in	60 mm-2,36 in
MY3S-5030	500 mm-19,62 in	300 mm-11,81 in	60 mm-2,36 in
MY3S-6030	600 mm-23,62 in	300 mm-11,81 in	60 mm-2,36 in
MY3/5S-7030	700 mm-27,56 in	300 mm-11,81 in	60 mm-2,36 in
MY3/5R-7430	740 mm-29,13 in	300 mm-11,81 in	90 mm-3,54 in
MY3/5R-8045	800 mm-31,40 in	450 mm-17,66 in	90 mm-3,54 in
MY3/5R-10035	1000 mm-39,37 in	350 mm-13,78 in	90 mm-3,54 in

Single Acting Cylinder mod. CLMY3000

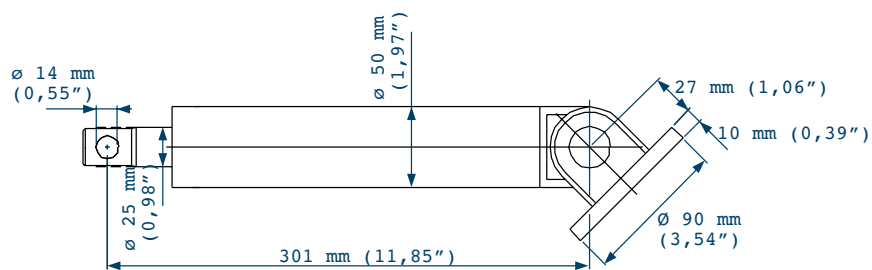
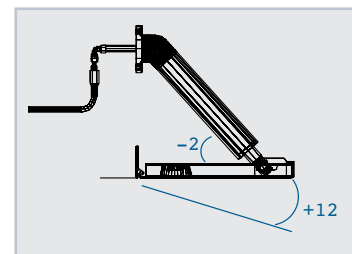

Technical Specifications

Model	Code	Type	Stroke	Volume	Thrust	Working Pressure	Fittings Thread	Weight
CLMY3000	IT12439	Single acting	55 mm 2,16 in	69/42 cc 4,2/2,5 cu.in	565 kgf 1243 lbf	45 bar 625 psi	G1/8"	5 kg 11 lb

Reversible Power Units mod. C097A / C099

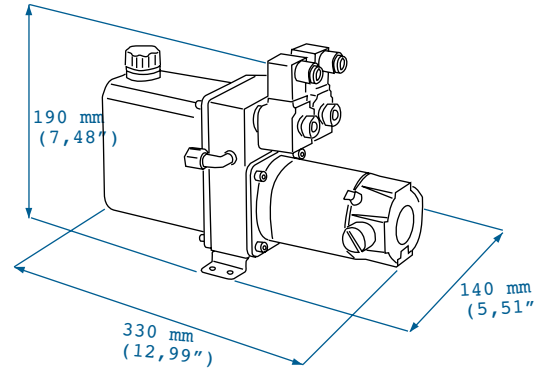

Technical Specifications

Model	Code	Voltage	Flow Rate	Pressure	Power Consumption	Tank Capacity	Fittings	Weight*	
C097A	IT12585	12V	960 cc 58,56 cu.in	45 bar	14 A	0,95 lt 57,97 cu.in	G1/4" - d.e. 6 mm G1/4" - 6 mm o.d.	5 kg 11 lb	
	IT17291	24V	960 cc 58,56 cu.in	652 psi	10,5 A				
C099	IT12588	12V	1920 cc 117,12 cu.in	45 bar	21 A	0,95 lt 57,97 cu.in			5 kg 11 lb
	IT17292	24V	1920 cc 117,12 cu.in	652 psi	16 A				

(*) Weight is intended without oil.

Reversing Kit for Power Unit mod. C097A / C099

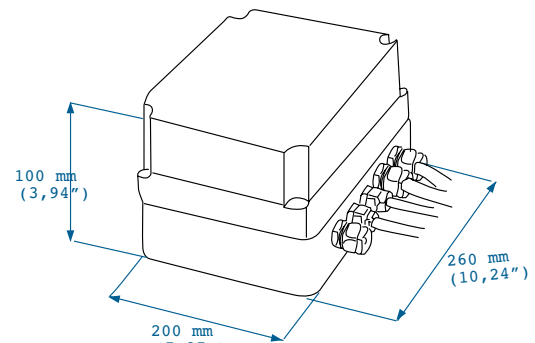

Code: 12 V = IT13666 24 V = IT13667

TRIM TAB SYSTEM COMPOSITION SERIES MY5000

Tab Kits

Model	Code	Description
MY3/5S - 7030	IT25088	Complete tabs kit simple type 27,56"x11,81"
MY3/5R - 7430	IT25090	Complete tabs kit reinforced type 29,13"x11,81"
MY3/5R - 8045	IT25093	Complete tabs kit reinforced type 31,40"x17,66"
MY3/5R - 10035	IT25094	Complete tabs kit reinforced type 39,37"x13,78"
MY4/5S - 6035	IT25101	Complete tabs kit simple type 23,62"x13,78"
MY4/5S - 8040	IT25102	Complete tabs kit simple type 31,40"x15,70"
MY4/5S - 9040	IT25104	Complete tabs kit simple type 35,43"x15,70"
MY4/5R - 8045	IT25163	Complete tabs kit reinforced type 31,40"x17,66"
MY4/5R - 9045	IT25111	Complete tabs kit reinforced type 35,43"x17,66"
MY4/5R - 10045	IT25110	Complete tabs kit reinforced type 39,37"x17,66"
MY4/5R - 10040	IT25115	Complete tabs kit reinforced type 39,37"x15,70"

Simple Tab Kit Composition mod. MY3/5S

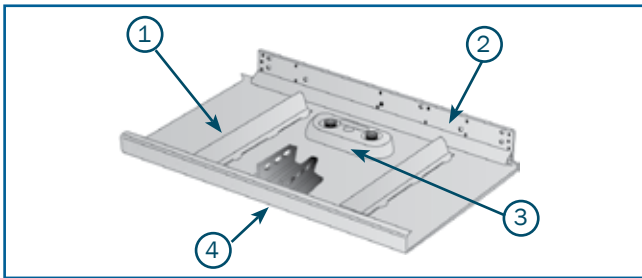

Position	Description	Qty.
1	Simple Tab	2
2	Hinge	2
3	Zinc anode	2
4	Cylinder connection	2

Reinforced Tab Kit Composition mod. MY3/5R

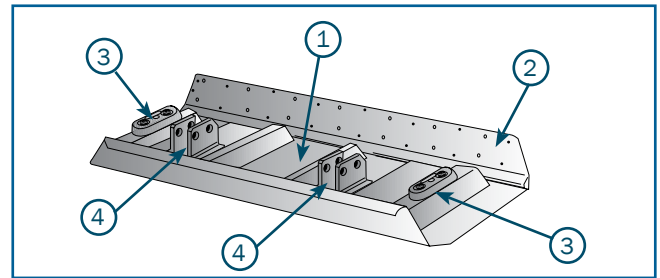

Position	Description	Qty.
1	Reinforced Tab	2
2	Hinge	2
3	Zinc anode	4
4	Cylinder connection	4

Simple Tab Kit Composition mod. MY4/5S

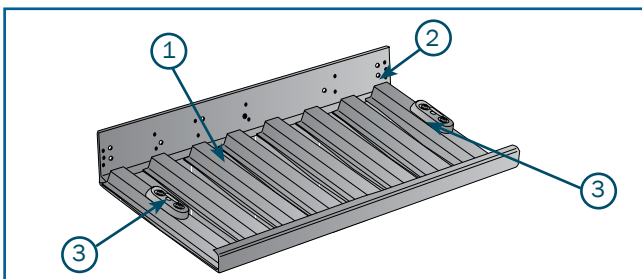

Position	Description	Qty.
1	Simple Trim Tab	2
2	Hinge	2
3	Zinc anode	4

Reinforced Tab Kit Composition mod. MY4/5R

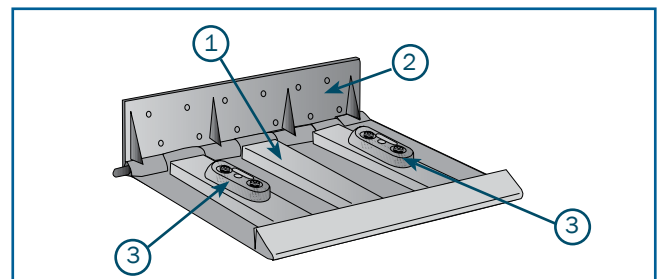

Position	Description	Qty.
1	Reinforced Trim Tab	2
2	Hinge with pin	2
3	Zinc anode	4

Note: For dimensions and main features see pages 18-19.

Hydraulic kits

Model		Code	Description
Combination with tab kit mod. MY3/5	MY50003/2-12	IT27467	Hydraulic kit with double acting cylinder - one cylinder each tab - 12V series 3000
	MY50003/2-24	IT26523	Hydraulic kit with double acting cylinder - one cylinder each tab - 24V series 3000
	MY50003/4-12	IT28541	Hydraulic kit with double acting cylinder - two cylinders each tab - 12V series 3000
	MY50003/4-24	IT27470	Hydraulic kit with double acting cylinder - two cylinders each tab - 24V series 3000
Combination with tab kit mod. MY4/5	MY50004/2-12	IT27471	Hydraulic kit with double acting cylinder - one cylinder each tab - 12V series 4000
	MY50004/2-24	IT28544	Hydraulic kit with double acting cylinder - one cylinder each tab - 24V series 4000
	MY50004/4-12	IT28543	Hydraulic kit with double acting cylinder - two cylinders each tab - 12V series 4000
	MY50004/4-24	IT27472	Hydraulic kit with double acting cylinder - two cylinders each tab - 24V series 4000

Optional Accessories

Model	Code	Description
PANEL	IT24766	Control panel
See pages 36-37 to choose type and purchase code		Trim tab angle indicator kit

Hydraulic Kit Composition mod. MY50003/2

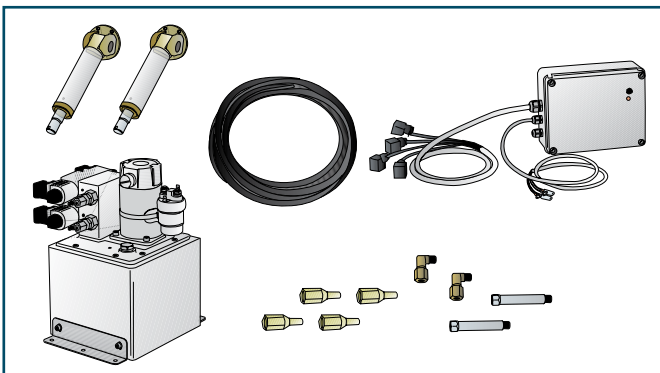

Description	Qty.
Double acting cylinders provided with pins for connection	2
Power unit mod. COMY1Q/B	1
Four functions electric wiring kit mod. KITEL4F/15	1
Flexible hose type R7 3/16"	12 mt-39 ft
Elbow fittings G1/8" - o.d. 6 mm	4
Reusable straight fittings hose type R7 3/16" - connector o.d. 6 mm	8
Through-hole G1/8" L=3,02 in.	2

Hydraulic Kit Composition mod. MY50004/2

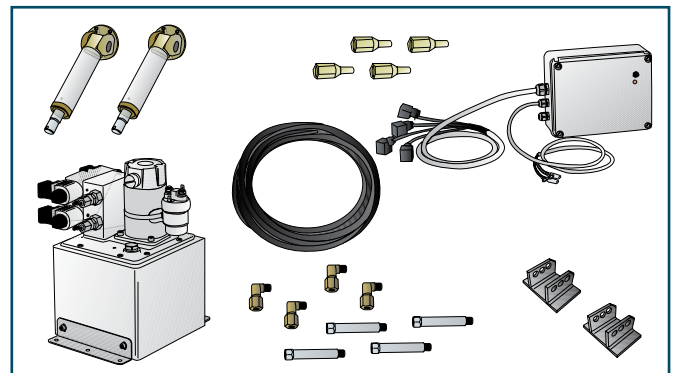

Description	Qty.
Double acting cylinders provided with pins for connection	2
Cylinder connection	2
Power unit mod. COMY1Q/B	1
Four functions electric wiring kit mod. KITEL4F/15	1
Flexible hose type R7 3/16"	12 mt-39 ft
Elbow fittings G1/8" - o.d. 6 mm	4
Reusable straight fittings hose type R7 3/16" - connector o.d. 6 mm	8
Through-hole G1/8" L=3,02 in.	4

Note: The hydraulic kit mod. MY50003/2 does not include the cylinder connection as it is welded on the tab.

Note: For dimensions and main features see pages 18-19.

Electrohydraulic Power Unit mod. COMY1Q/B

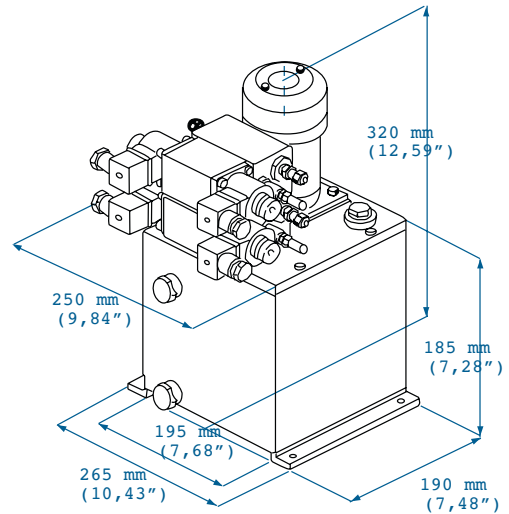

Technical Specifications

Model	Code	Voltage	Flow Rate	Pressure	Power Consumption	Tank Capacity	Fittings	Weight
COMY1Q/B	IT24089	12V	306 cc 18,67 cu.in	90 bar 1305 psi	17 A	5 lt 305 cu.in	G 1/4" - d.e. 6 mm G 1/4" - 6 mm o.d.	15 kg 33 lb
	IT23481	24V	760 cc 46,98 cu.in		15 A			

(*) Weight is intended without oil.

Electric Wiring Kit for Power Unit mod. COMY1Q/B

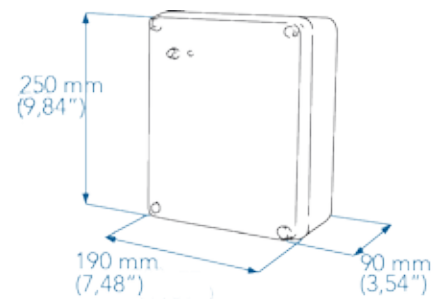

Code: 12-24 V = IT30231

TRIM TAB SYSTEM COMPOSITION SERIES MY4000

Tab Kits

Model	Code	Description
MY4/5S - 6035	IT25101	Complete tabs kit simple type 23,62"x13,78"
MY4/5S - 8040	IT25102	Complete tabs kit simple type 31,40"x15,70"
MY4/5S - 9040	IT25104	Complete tabs kit simple type 35,43"x15,70"
MY4/5R - 8045	IT25163	Complete tabs kit reinforced type 31,40"x17,66"
MY4/5R - 9045	IT25111	Complete tabs kit reinforced type 35,43"x17,66"
MY4/5R - 10045	IT25110	Complete tabs kit reinforced type 39,37"x17,66"
MY4/5R - 10040	IT25115	Complete tabs kit reinforced type 39,37"x15,70"
MY4R - 12040	IT25119	Complete tabs kit reinforced type 47,24"x15,70"
MY4R - 15050	IT25123	Complete tabs kit reinforced type 59,05"x19,62"
MY4R - 15045	IT25160	Complete tabs kit reinforced type 59,05"x17,66"
MY4R - 20045	IT25125	Complete tabs kit reinforced type 78,74"x17,66"
MY4R - 20050	IT25127	Complete tabs kit reinforced type 78,74"x19,62"

Simple Tab Kit Composition

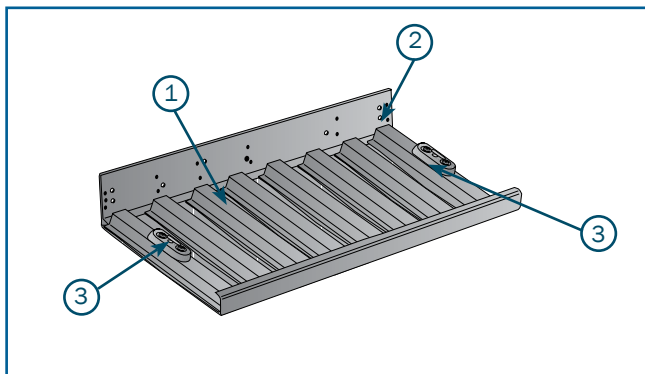

Position	Description	Qty.
1	Simple Trim Tab	2
2	Hinge	2
3	Zinc anode	4

Reinforced Tab Kit Composition

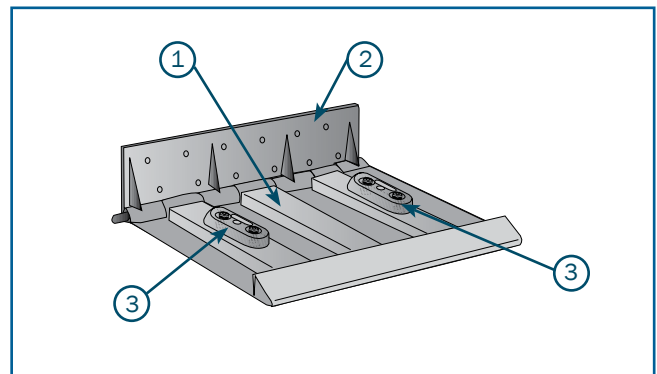

Position	Description	Qty.
1	Reinforced Trim Tab	2
2	Hinge with pin	2
3	Zinc anode	4

Note: The tabs of series MY4000 are provided without cylinder connection as they are usually included in the hydraulic kit. To order tab kit only please specify if the cylinder connection should be added. For dimensions and main features see pages 22-23.

Hydraulic Kits

Model	Code	Description
MY4000/2-12	IT25128	Hydraulic kit with double acting cylinder - one cylinder each tab - 12V
MY4000/2-24	IT25131	Hydraulic kit with double acting cylinder - one cylinder each tab - 24V
MY4000/4-12	IT25132	Hydraulic kit with double acting cylinder - two cylinders each tab - 12V
MY4000/4-24	IT25133	Hydraulic kit with double acting cylinder - two cylinders each tab - 24V
MY4000S/2-24	IT27474	Hydraulic kit with double acting cylinder with built-in sensor - one cylinder each tab - 24V
MY4000S/4-24	IT27478	Hydraulic kit with double acting cylinder with built-in sensor - two cylinders each tab - 24V

Optional Accessories

Model	Code	Description
PANEL	IT24766	Control panel
See page 36 to choose type and purchase code		Trim tab angle indicator kit

Hydraulic Kit Composition mod. MY4000/2-MY4000S/2

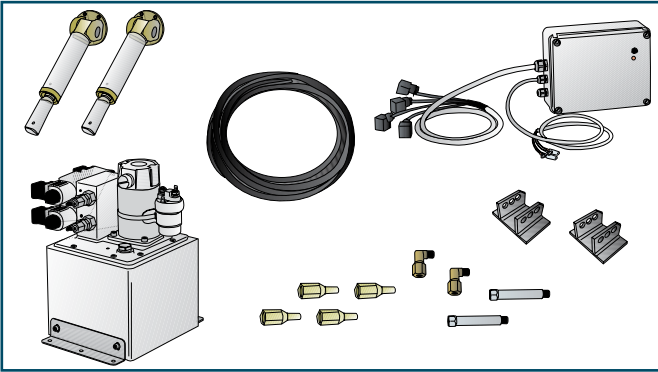

Description	Qty.
Double acting cylinders provided with pins for connection	2
Cylinder connection	2
Power unit mod. COMY1Q/B	1
Four functions electric wiring kit mod. KITEL4F/15	1
Flexible hose type R7 3/16"	12 mt 39 ft
Elbow fittings G1/8" - o.d. 6 mm	4
Reusable straight fittings hose type R7 3/16" - connector o.d. 6 mm	8
Through-hole G1/8" L=3,02 in.	4

Hydraulic Kit Composition mod. MY4000/4-MY4000S/4

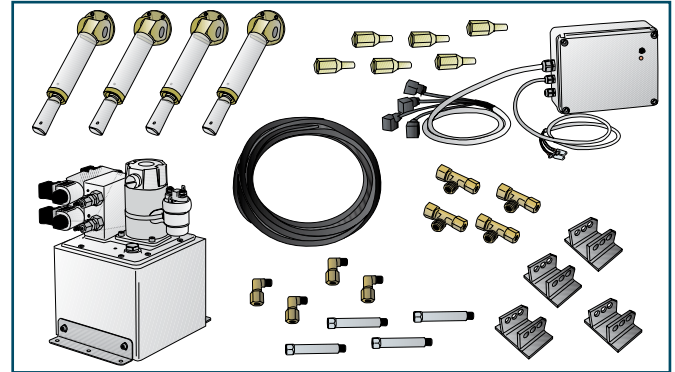

Description	Qty.
Double acting cylinders provided with pins for connection	4
Cylinder connection	4
Power unit mod. COMY1Q/B	1
Four functions electric wiring kit mod. KITEL4F/15	1
Flexible hose type R7 3/16"	12 mt 39 ft
Elbow fittings G1/8" - o.d. 6 mm	4
Tee fittings G1/8" - o.d.6 mm	4
Reusable straight fittings hose type R7 3/16" - connector o.d. 6 mm	12
Through-hole G1/8" L=3,02 in.	8

MAIN FEATURES OF SERIES MY4000 TRIM TAB SYSTEM COMPONENTS

Trim Tab Dimensions

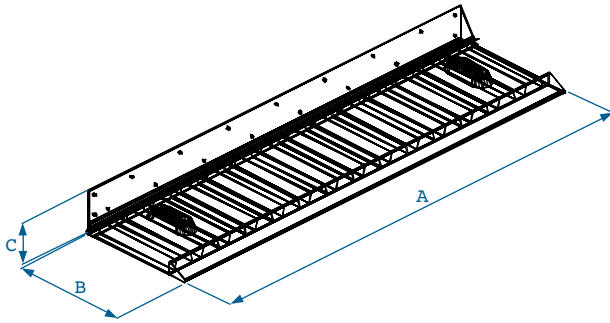

Model	Dimensions		
	A	B	C
MY4/5S - 6035	600 mm - 23,62 in	350 mm - 13,78 in	120 mm - 4,72 in
MY4/5S - 8040	800 mm - 31,40 in	400 mm - 15,70 in	120 mm - 4,72 in
MY4/5S - 9040	900 mm - 35,43 in	400 mm - 15,70 in	120 mm - 4,72 in
MY4/5R - 8045	800 mm - 31,40 in	450 mm - 17,66 in	120 mm - 4,72 in
MY4/5R - 9045	900 mm - 35,43 in	450 mm - 17,66 in	120 mm - 4,72 in
MY4/5R - 10045	1000 mm - 39,37 in	450 mm - 17,66 in	120 mm - 4,72 in
MY4/5R - 10040	1000 mm - 39,37 in	400 mm - 15,70 in	120 mm - 4,72 in
MY4R - 12040	1200 mm - 47,24 in	400 mm - 15,70 in	120 mm - 4,72 in
MY4R - 15045	1500 mm - 59,05 in	450 mm - 17,66 in	120 mm - 4,72 in
MY4R - 15050	1500 mm - 59,05 in	500 mm - 19,62 in	120 mm - 4,72 in
MY4R - 20045	2000 mm - 78,74 in	450 mm - 17,66 in	120 mm - 4,72 in
MY4R - 20050	2000 mm - 78,74 in	500 mm - 19,62 in	120 mm - 4,72 in

Double Acting Cylinder Mod. CLMY4000

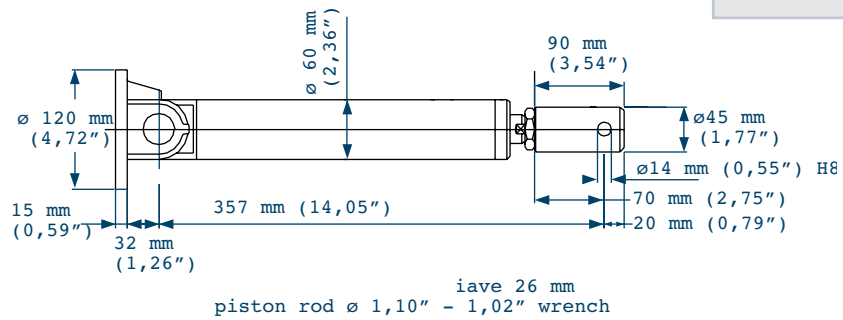
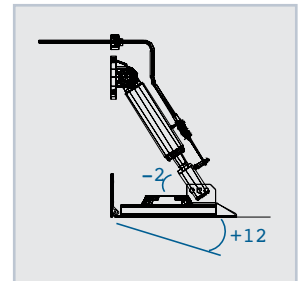

Technical Specifications

Model	Code	Type	Stroke	Volume	Thrust	Working Pressure	Fittings Thread	Weight
CLMY4000	IT10568	Double acting	104 mm 4.09 in	130,62/66,66 cc 7,97/4,06 cu.in	1130 kgf 2486 lbf	90 bar 1305 psi	G1/8"	10 kg 22 lb

NEW CYLINDER MY4000S WITH BUILT-IN SENSOR

With the goal of optimal performance, Twin Disc has researched, designed and manufactured a new system for trim tab angle detection using the Hall effect sensor technology.

This system uses a double acting cylinder mod. MY4000 with a sensor, which detects and transmits the tab inclination angle. The signal is sent directly to the electronic control panel through a flexible hose which is UV and water resistant.

The system configuration is much simpler with faster installation, as the traditional transmission kit is no longer necessary. The cylinder also assures the transmission system a longer life, as there are no external hoses that could corrode. The cylinder also does not contain electric sliding contacts, which are normally subjected to wear. The cylinder can be used either in combination with all the tabs of the series MY4000 or with the aluminium trim tab systems mod. MY40001. (See pages 36-37).

Double Acting Cylinder Built-in Sensor Mod. CLMY4000S

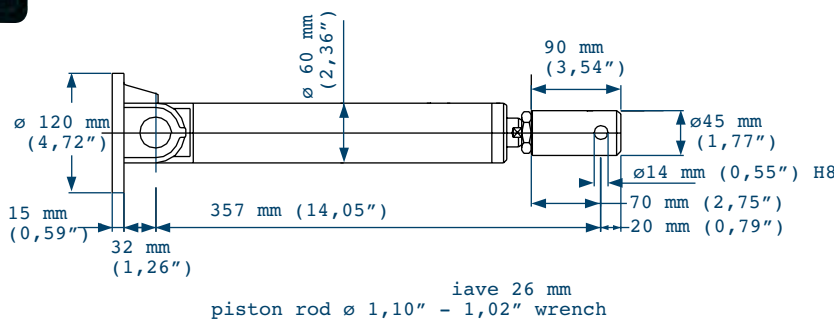
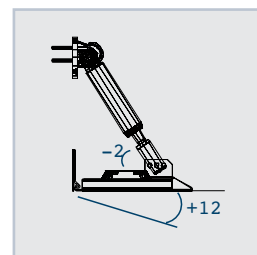

Technical Specifications

Model	Code	Type	Stroke	Volume	Thrust	Working Pressure	Fittings Thread	Weight
CLMY4000S	IT26225	Double acting	104 mm 4.09 in	130,62/66,66 cc 7,97/4,06 cu.in	1130 kgf 2486 lbf	90 bar 1305 psi	G1/8"	10 kg 22 lb

Electrohydraulic Power Unit mod. COMY1Q/B

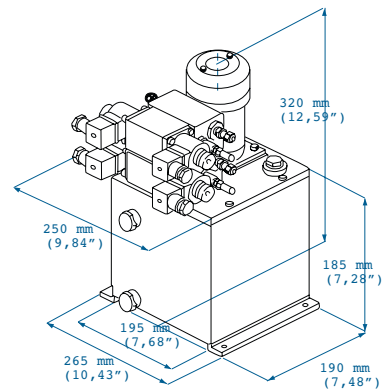

Technical Specifications

Model	Code	Voltage	Flow Rate	Pressure	Power Consumption	Tank Capacity	Fittings	Weight
COMY1Q/B	IT24089	12V	306 cc 18,67 cu.in	90 bar 1305 psi	17 A	5 lt 305 cu.in	G 1/4" - d.e. 6 mm G 1/4" - 6 mm o.d.	15 kg
	IT23481	24V	760 cc 46,98 cu.in		15 A			33 lb

(*) Weight is intended without oil.

Electric Wiring Kit for Power Unit mod. COMY1Q/B

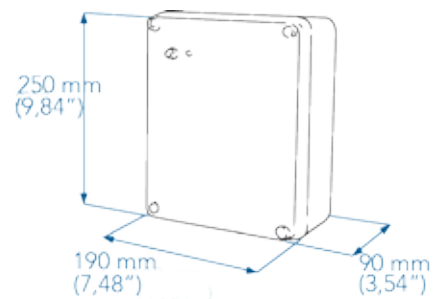

Code: 12-24 V = IT30231



MAIN FEATURES OF ALUMINUM TRIM TAB SYSTEMS

Suitable for high speed boats (over 40 knots), the aluminium trim tab systems are available in a wide variety of dimensions and shapes, which will satisfy most requirements and applications.

A large selection of accessories is available to complete the system and helps to make the system much easier and more efficient to use. For a detailed description, see page 36.

HINGE

The hinge is the firm component of the system. It is directly fixed to the transom and the tab is connected by means of long stainless steel pins passing through the slotted holes of both.

The hinge is provided with the holes and their through-holes for the passage of the external hoses going inside the boat. The hinge is also supplied with the connection holes for the hydraulic cylinder mounting.

1



HYDRAULIC CYLINDER

The hydraulic cylinder is the real “power source” of the trim tab system. It is connected to the tab and causes its deflection movement. All aluminium trim tab systems are provided with double acting hydraulic cylinders, i.e. a cylinder whose piston is hydraulically pushed out and pulled back again for a more powerful action.

The cylinder is provided with external hoses that are directly connected to the tab hinge and transom. Both the piston rod and cylinder body are in stainless steel, for the best corrosion resistance.

2

3

TAB

Due to their specific application on high-speed boats, the aluminum tabs have a limited width and longer length. Cast of the best quality special aluminum alloy, they are highly-resistant to corrosion. They are treated to guarantee a strong resistance to electrolysis, provided they are installed properly, and painted to withstand high speeds. Every tab is provided with necessary slotted holes for the hydraulic cylinder mounting.

4

ZINC ANODE

Zinc material is able to protect the tabs against the galvanic currents that normally develop between different metals. The anode is placed in the central part of each tab. Mod. MY40001, which is a larger tab, contains two anodes on each.

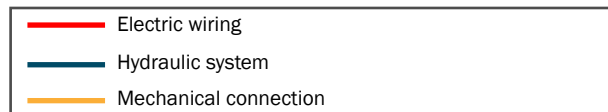
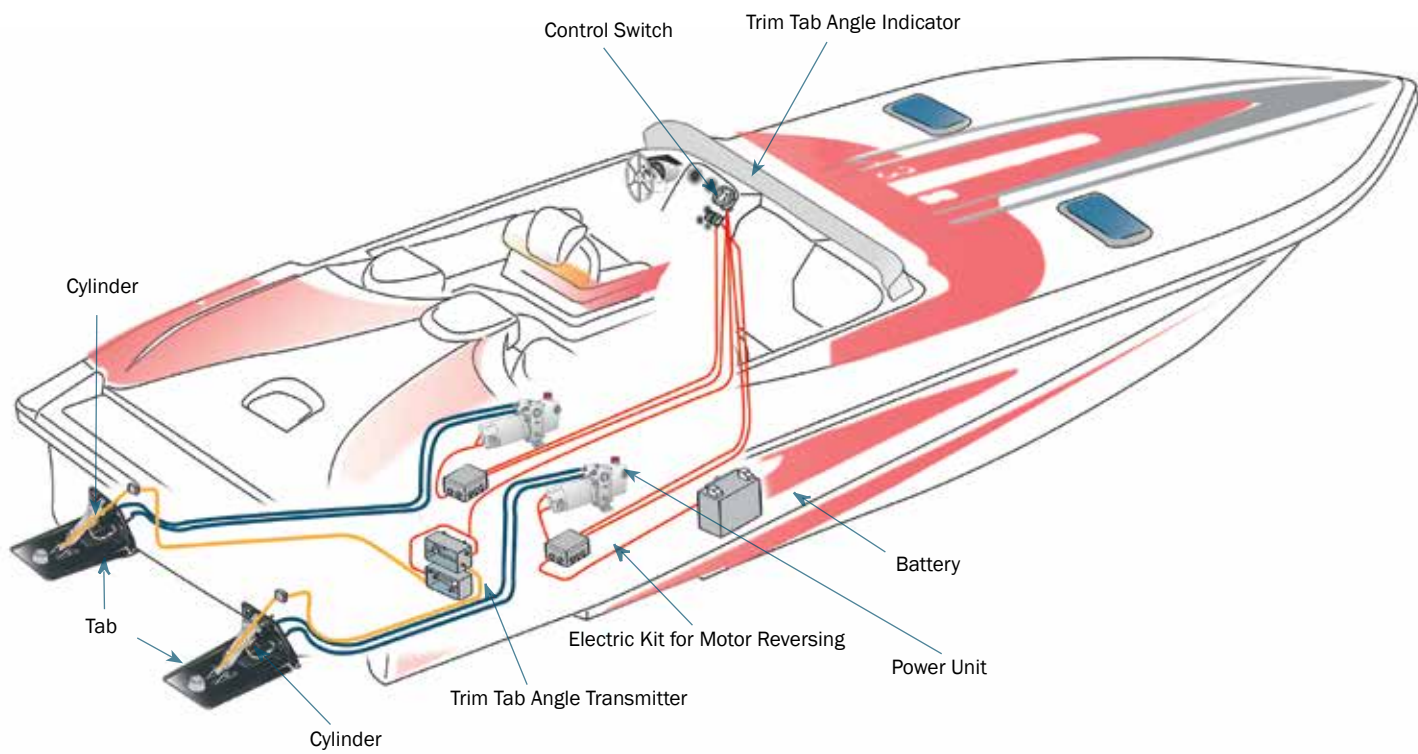

ALUMINUM TRIM TAB SYSTEM SELECTION

To choose a suitable aluminum trim tab system, it is important to consider the same important factors as for the stainless steel systems such as the maximum speed, boat dimensions and displacement.

We have prepared a simple Order Guide table (below). Starting with the boat type (with speed over 40 knots), it is enough to select the boat length and the full-load displacement to obtain the model suggested for the specific application.

The models listed on the table below refer to a complete system, i.e. already provided with both the tab and the electrohydraulic kits.
Example: For a boat with the following characteristics, mod. MY10001 at 12 or 24 V is suggested:

- speed > 40 Knots
- length 15 mt
- weight < 30 Ton.

Order codes: IT15764 or IT15765

The Order Guide is intended as indicative and as a general reference. For questions about a specific application, please consult the Twin Disc Technical Dept. or one of our authorized dealers.

How to Order

Boat Type	Boat Length LOA	Displacement	Suggested System		Catalog Page	Accessories	
			Model	Code		Control Panel	Angle Transmitter Kit
High speed boats > 40 knots 	6,10 - 18,60 mt 20' - 55'	< 30 Tons	MY10001-12	IT15764	30	code: IT24766 For more details see pages 36-37	Choose the model and the code of the trim tab angle indicator according to the selections table on page 36
			MY10001-24	IT15765			
	16,60 - 27 mt 55' - 80'	< 42 Tons	MYOFF2-12	IT15766	32		
			MYOFF2-24	IT15767			
			MYOFF6-12*	IT15761	32		
			MYOFF6-24*	IT15762			
	27 - 33,50 80' - 110'	<133 Tons	MY40001-12	IT15751	34		
			MY40001-24	IT15752			

(*) Suggested applications for boats provided with surface drives.

Trim Tab Systems MY10001 - MYOFF2 - MYOFF6 - MY40001

Model	Code	Description
MY10001 - 12	IT15764	Aluminum trim tabs system mod. MY10001 - 12,95" x 20,80" - 12V
MY10001 - 24	IT15765	Aluminum trim tabs system mod. MY10001 - 12,95" x 20,80" - 24V
MYOFF2 - 12	IT15766	Aluminum trim tabs system mod. MYOFF2 - 15,70" x 24,25" - 12V
MYOFF2 - 24	IT15767	Aluminum trim tabs system mod. MYOFF2 - 15,70" x 24,25" - 24V
MYOFF6 - 12	IT15761	Aluminum trim tabs system mod. MYOFF6 - 14,71" x 29,43" - 12V
MYOFF6 - 24	IT15762	Aluminum trim tabs system mod. MYOFF6 - 14,71" x 29,43" - 24V
MY40001-12	IT15751	Aluminum trim tabs system mod. MY4000 - 22,60" x 31,79" - 12V
MY40001-24	IT15752	Aluminum trim tabs system mod. MY40001 - 22,60" x 31,79" - 24V

COMPOSITION OF ALUMINUM TRIM TAB SYSTEMS

Every aluminium trim tab system listed on the previous page must be intended as a 'COMPLETE system', i.e. provided with both the tab and the electrohydraulic kits: cylinders, power units, electric kits and all necessary fittings and hoses.

Trim Tab Systems Composition Mod. MY10001 - MYOFF2 - MYOFF6

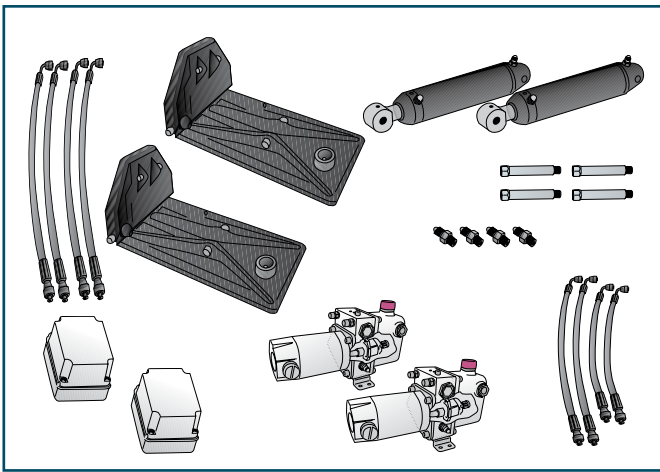

Description	Qty.
Aluminum trim tabs	2
Zinc anode	2
Double acting cylinders	2
Power unit mod. COMYR	2
Electric kit for motor reversing mod. KITIM501 or 502	2
G 1/8" fittings	8
Flexible hoses type R7 3/16" with braided in s/steel and fittings	4x1 mt
Flexible long hoses type R7 3/16" with braided in s/steel and fittings	2x0,35 mt
Flexible short hoses type R7 3/16" with braided in s/steel and fittings	2x0,55 mt
Hinge and tab cylinder connection pins	4
Through-hole G1/8" L=3,02 in.	4

Trim Tab Systems Composition Mod. MY40001

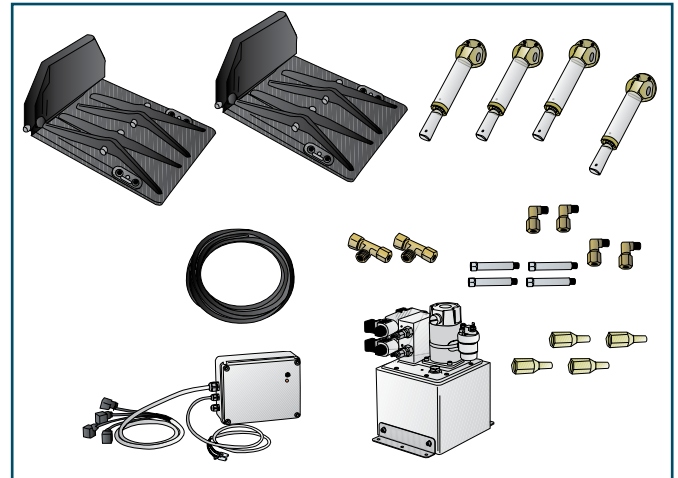

Description	Qty.
Aluminum trim tabs	2
Zinc anode	4
Double acting cylinders provided with pin	4
Power unit mod. COMY1Q/B	1
Four functions electric wiring kit mod. KITEL4F/15	1
Elbow fittings G 1/8" - o.d. 6 mm	8
Tee fittings G 1/8" - o.d. 6 mm	4
Reusable straight fittings hoses type R7 3/16" - connector o.d. 6 mm	8
Flexible hoses type R7 3/16"	13 mt-42 ft
Tab cylinder connection pins	4
Through-hole G1/8" L=13,74 in.	8

TRIM TAB SYSTEM MOD. MY10001

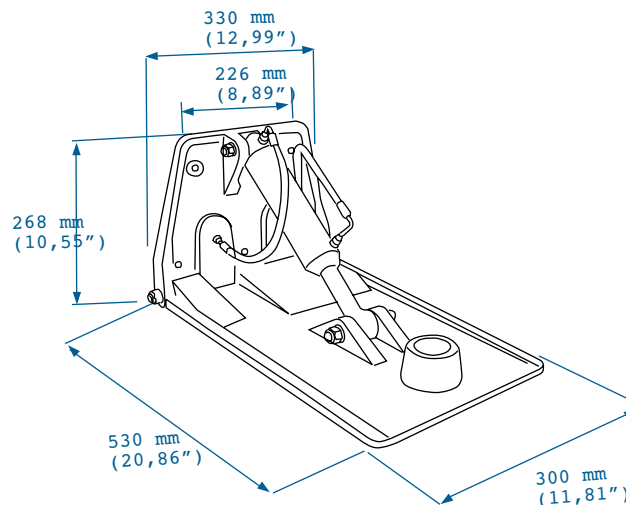

IMPORTANT

For the application of this trim tab system, the transom inclination shall be from +6° to +21°.

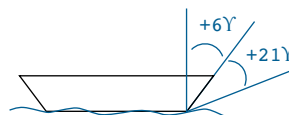

ORDER GUIDE

Model	Code	Description
MY10001 - 12	IT15764	Aluminum trim tabs system mod. MY10001 - 12,95" x 20,80" - 12V
MY10001 - 24	IT15765	Aluminum trim tabs system mod. MY10001 - 12,95" x 20,80" - 24V

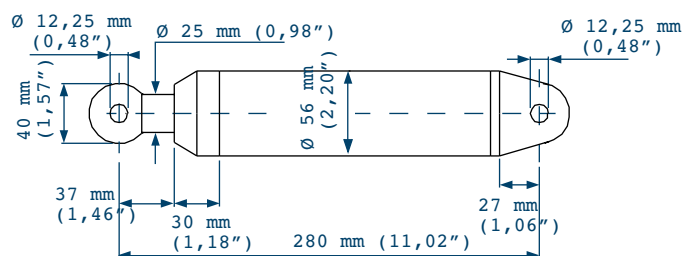

Main Features of Cylinder mod. CLMY1000

Technical Specifications								
Model	Code	Type	Stroke	Volume	Thrust	Working Pressure	Fittings Thread	Weight
CLMY1000	IT12494	Double acting	106 mm 4,17 in	176/174 cc 10,74/7,56 cu.in	1046 kg 2301 lbf	63 bar 913 psi	G1/8"	3,7 kg 8,14 lb

TRIM TAB SYSTEM MOD. MYOFF2

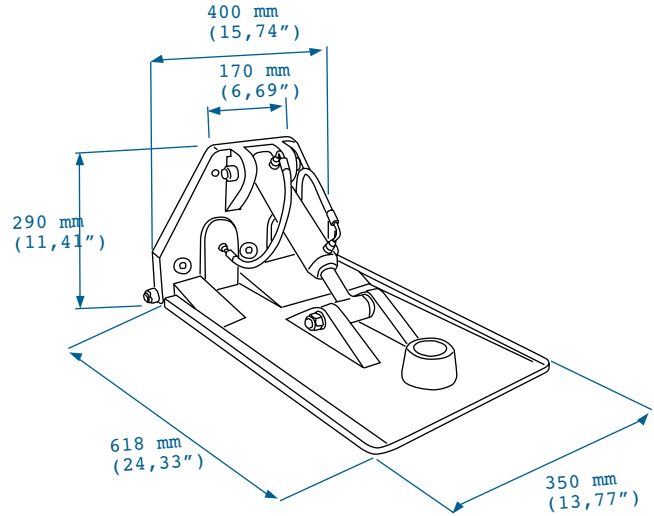

IMPORTANT
For the application of this trim tab system, the transom inclination shall be from +9° to +21°.

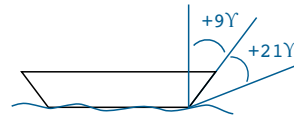

ORDER GUIDE

Model	Code	Description
MYOFF2 - 12	IT15766	Aluminum trim tabs system mod. MYOFF2 - 15,70" x 24,25" - 12V
MYOFF2 - 24	IT15767	Aluminum trim tabs system mod. MYOFF2 - 15,70" x 24,25" - 24V

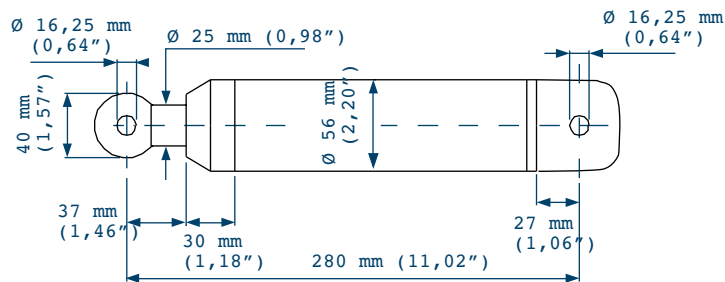

Main Features of Cylinder mod. CLMY1000AB

Technical Specifications								
Model	Code	Type	Stroke	Volume	Thrust	Working Pressure	Fittings Thread	Weight
CLMY1000AB	IT16143	Double acting	106 mm 4,17 in	176/174 cc 10,74/7,56 cu.in	1046 kg 2301 lbf	63 bar 913 psi	G1/8"	4 kg 8,8 lb

TRIM TAB SYSTEM MOD. MYOFF6

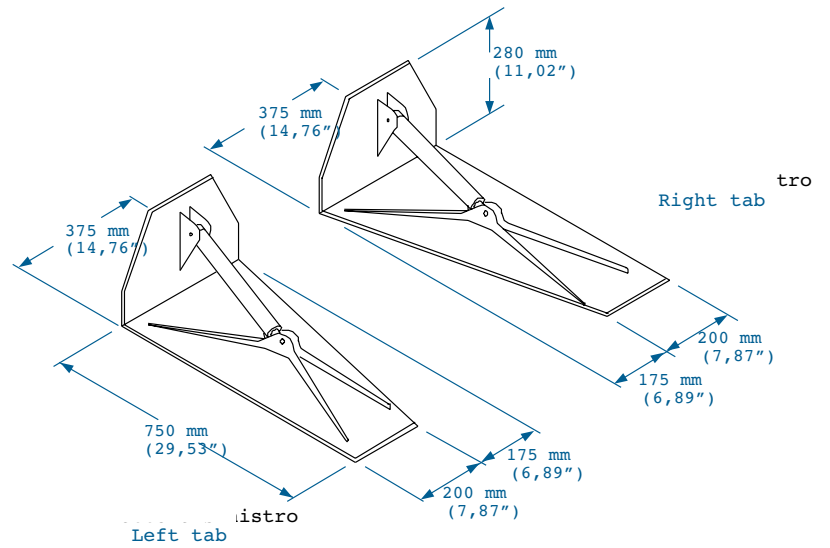

▲ IMPORTANT

For the application of this trim tab system, the transom inclination shall be from -14° to $+7^{\circ}$.

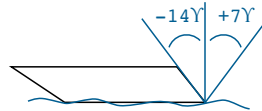

ORDER GUIDE

Model	Code	Description
MYOFF6 - 12	IT15761	Aluminum trim tabs system mod. MYOFF6 - 14,71" x 29,43" - 12V
MYOFF6 - 24	IT15762	Aluminum trim tabs system mod. MYOFF6 - 14,71" x 29,43" - 24V

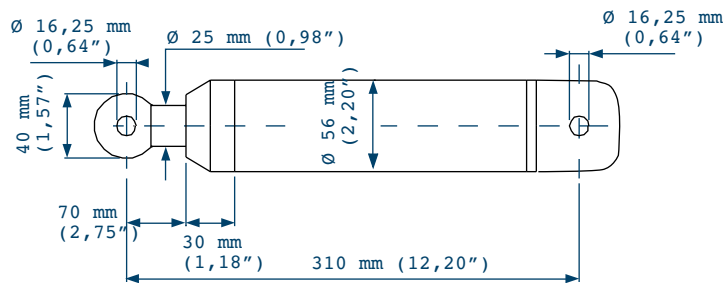

Main Features of Cylinder mod. CLMY1000C

Technical Specifications								
Model	Code	Type	Stroke	Volume	Thrust	Working Pressure	Fittings Thread	Weight
CLMY1000C	IT12421	Double acting	106 mm 4,17 in	176/124 cc 10,74/7,56 cu.in	1046 kgf 2301 lbf	63 bar 913 psi	G1/8"	4 kg 8,8 lb

ELECTROHYDRAULIC COMPONENTS FOR TRIM TAB SYSTEMS MOD. MY10001 - MYOFF2 - MYOFF6

Reversing Kit for Power Unit mod. COMYR

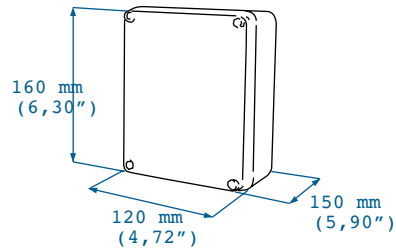

Code: IT13672 - 12V
IT13673 - 24V

Power Unit mod. COMYR

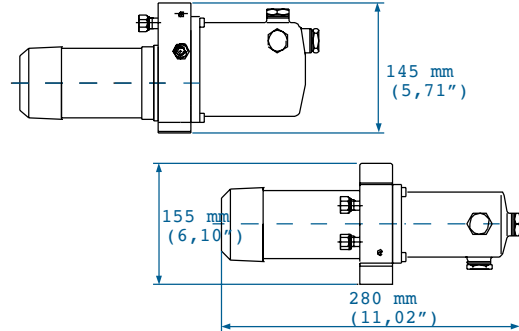

Technical Specifications								
Model	Code	Voltage	Flow Rate	Pressure	Power Consumption	Tank Capacity	Fittings	*Weight
COMYR	IT12628	12V	960 cc	63 bar	22 A	0,55 lt	G1/4" fittings	4,4 kg
COMYR	IT12630	24V	56,58 cu.in	913 psi	10 A	33,56 cu.in		9,68 lb

(*) Weight is intended without oil.

▲ IMPORTANT

Due to the special tab shape, the trim tab system mod. MYOFF6 is particularly suggested for the installation on boats provided with surface drives. The tab is straight on the external side and sloping on the internal side, in order to prevent any kind of interference with the movement of the drive.

TRIM TAB SYSTEM MOD. MY40001

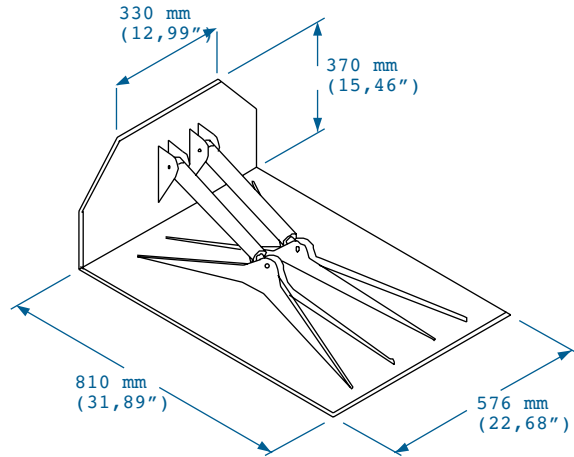

ORDER GUIDE

Model	Code	Description
MY40001-12	IT15751	Aluminum trim tabs system mod. MY40000 - 22,60" x 31,79" - 12V
MY40001-24	IT15752	Aluminum trim tabs system mod. MY40001 - 22,60" x 31,79" - 24V

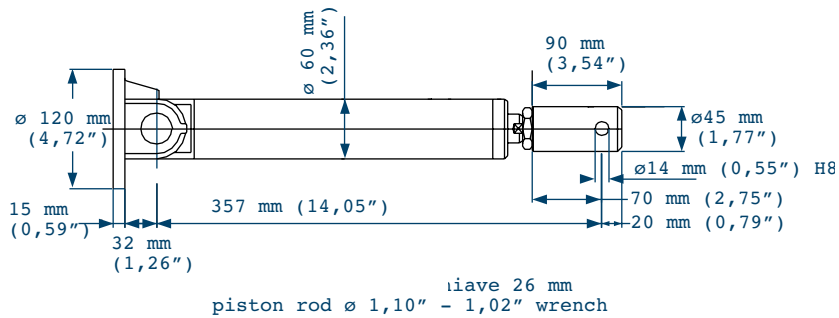

Main Features of Cylinder mod. CLMY4000

Technical Specifications								
Model	Code	Type	Stroke	Volume	Thrust	Working Pressure	Fittings Thread	Weight
CLMY 4000	IT10568	Double acting	104 mm 4.09 in	130,62/66,66 cc 7,97/4,06 cu.in	1130 kgf 2486 lbf	90 bar 1305 psi	G1/8"	10 kg 22 lb

ELECTROHYDRAULIC COMPONENTS FOR TRIM TAB SYSTEMS MOD. MY40001

Electric Wiring Kit for Power Unit mod. COMY1Q/B - Standard Control Box

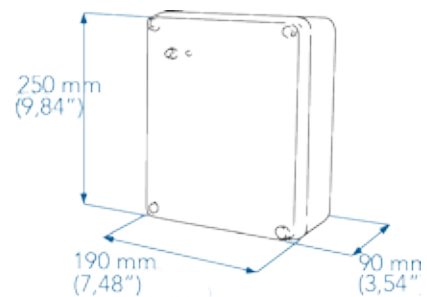

Code: 12-24V = IT13659

Power Unit mod. COMY1Q/B

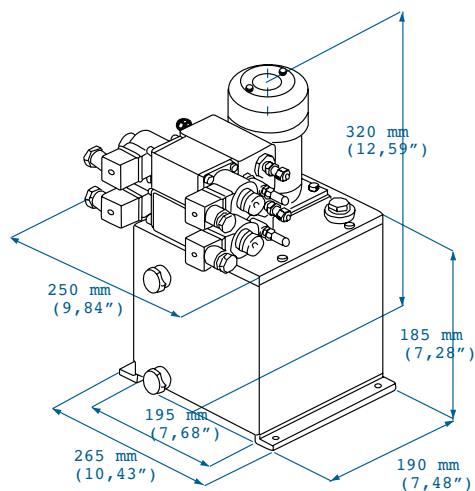

Technical Specifications								
Model	Code	Voltage	Flow Rate	Pressure	Power Consumption	Tank Capacity	Fittings	*Weight
COMY1Q/B	IT24089	12V	306 cc	90 bar 1305 psi	17 A	5 lt 305 cu.in	G 1/4" - d.e. 6 mm G 1/4" - 6 mm o.d.	15 kg
			18,67 cu.in					
	IT23481	24V	770 cc		15 A			33 lb
			46,98 cu.in					

(* Weight is intended without oil.

ACCESSORIES

The stainless steel and aluminium trim tab systems can be combined with a wide range of accessories that complete the systems and make their use easier and more efficient.

Trim Tab Angle Indicator Kit

The trim tab angle indicator set shows the cylinder's inclination angle on a scale from -2° to $+12^{\circ}$. It is available in single or double scale and for single or dual station. The indicator set allows continuous control of the tab position and its many possible adjustments.

The mechanical working principle is very simple: the potentiometer records the cylinder movement and transmits it to the angle indicator on the bridge dashboard. With the cylinder mod. MY4000S containing a built in sensor, the tab inclination angle is detected by the device. The external transmission kit is no longer necessary as the sensor itself sends the signal directly to the trim angle indicator.

How to Order

	Type of System	# of Stations	Type of Angle Indicator	Model	Purchase Code of the Angle Indicator Kit
Stainless steel systems speed <40 knots	Trim tab system series MY3000- MY5000	Single	d. 52 mm - 2,05 in 12-24 V	K-IND52S	IT25244
			d. 80 mm - 3,14 in 12-24 V	K-IND80S	IT25245
		Dual	d. 52 mm - 2,05 in 12-24 V	K-IND52D	IT25246
			d. 80 mm - 3,14 in 12-24 V	K-IND80D	IT25247
	Trim tab system series MY4000*	Single	d. 52 mm - 2,05 in 12-24 V	K-IND52S	IT25248
			d. 80 mm - 3,14 in 12-24 V	K-IND80S	IT25249
		Dual	d. 52 mm - 2,05 in 12-24 V	K-IND52D	IT25250
			d. 80 mm - 3,14 in 12-24 V	K-IND80D	IT25251
Aluminium systems speed >40 knots	Aluminum system	Single	d. 52 mm - 2,05 in 12-24 V	K-IND52S	IT25248
			d. 80 mm - 3,14 in 12-24 V	K-IND80S	IT25249
		Dual	d. 52 mm - 2,05 in 12-24 V	K-IND52D	IT25250
			d. 80 mm - 3,14 in 12-24 V	K-IND80D	IT25251

(* In case cylinder mod. CLMY4000S is installed, it is necessary to order the electronic control panel. For further details, see pages 9 and 23.

Composition of Trim Tab Indicator mod. K-IND52S

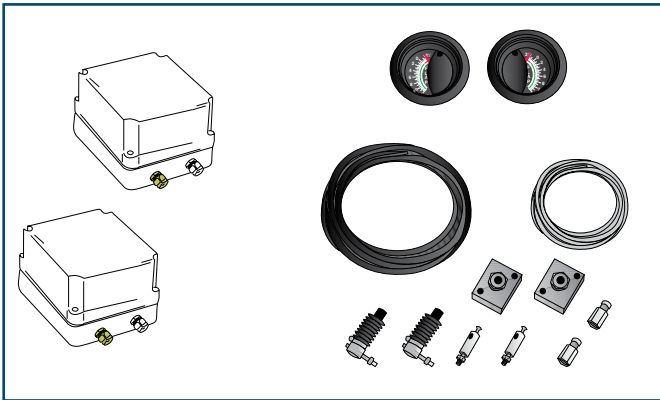

Description	Qty.
Single station trim tab angle indicator d. 52 mm - 2,05 in	2
Water-tight boxes of trim tab angle transmitter	2
Trim tab angle transmitter kit	1

Composition of Trim Tab Indicator mod. K-IND52D

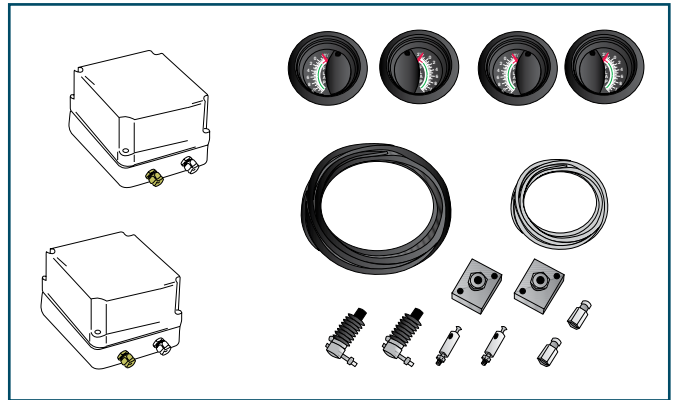

Description	Qty.
Dual station trim tab angle indicator d. 52 mm - 2,05 in	4
Water-tight boxes of trim tab angle transmitter	2
Trim tab angle transmitter kit	1

Composition of Trim Tab Indicator mod. K-IND80S

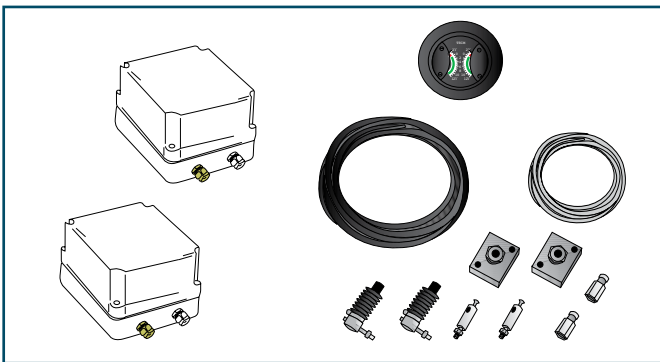

Description	Qty.
Single station trim tab angle indicator d. 80 mm - 3,14 in	1
Water-tight boxes of trim tab angle transmitter	2
Trim tab angle transmitter kit	1

Composition of Trim Tab Indicator mod. K-IND80D

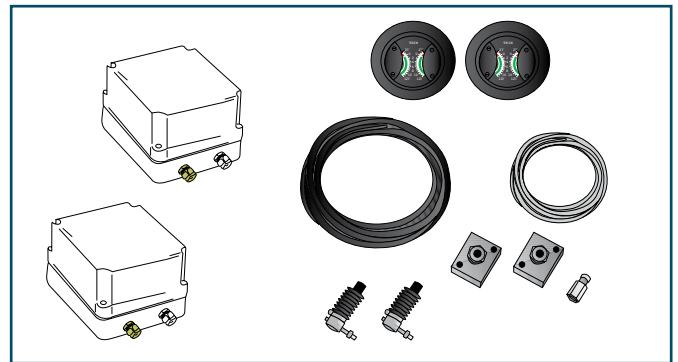

Description	Qty.
Dual station trim tab angle indicator d. 80 mm - 3,14 in	2
Water-tight boxes of trim tab angle transmitter	2
Trim tab angle transmitter kit	1



INTERNATIONAL DISTRIBUTORS

Asia

TWIN DISC (FAR EAST) PTE LTD

6, Tuas Avenue 1
Singapore 639491
Phone: (65) 6267 0800
Fax: (65) 6264 2080
Email: enquiry@twindisc.com.sg

Pacific Territories

TWIN DISC (PACIFIC) PTY LTD - BRISBANE

40 Telford Street
Virginia QLD 4014
Phone: +61 (7) 3265-1200
Fax: +61 (7) 3865-1371
Email: twindisc.brisbane@twindisc.com.au

Mailing Address:

PO Box 442
Virginia QLD 4014
Australia

North America

TWIN DISC SOUTHEAST INC.

8226 Phillips Highway
Jacksonville, FL USA 32256
Phone: +1 (904) 380-3196
Phone: +1 (888) 689-5355
Fax: +1 (904) 380-3197
Email: info@twindiscse.com
www.twindiscse.com

Latin America

TWIN DISC, INCORPORATED

3505 Lake Lynda Drive, Suite 200
Orlando, FL USA 32817
Phone: +1 (407) 574-3357

Europe, Middle East and Africa

TWIN DISC SRL

Via E. e P. Salani 1
50050 Limite Sull'Arno (FI)
Italy
Phone: +39 0571 979111
Fax: +39 0571 979143

For local distributors, please visit the Sales & Service
Locator page at www.twindisc.com

WARRANTY CONDITIONS

See Company Literature page at www.twindisc.com for warranty information.



Photographs
Pubbli Photo
di Cinelli Silvano

All rights are reserved.
Any reproduction of this catalogue, even partial,
is absolutely forbidden without a written
authorization of the copyright owner.

Copyright © 2015 TWIN DISC

Due to constant improvement, technical
specifications and dimensions can be modified
without previous notice.

Printed August 2015



Via E. e P. Salani, 1 - 50050 Limite Sull'Arno (Fi) Italy - Tel. +39 0571 97911 Fax +39 0571 979143 - www.twindisc.com

Authorized dealer