



HYDROTECHNIK

DIAGNOSTIC TEST EQUIPMENT

HYDROTECHNIK DIAGNOSTIC TEST EQUIPMENT: INNOVATIVE TECHNOLOGY YOU CAN COUNT ON



Dennis Schütze
Product Manager
DIAGNOSTIC TEST EQUIPMENT

Using innovative solutions to set industry trends

To keep your hydraulic system running smoothly, you need to constantly monitor pressure, temperature and flow.

Recording data gives you a base point from which to evaluate your test results.

Hydrotechnik carries a broad range of diagnostic equipment that interfaces with professional software, making it the perfect tool to use in your condition monitoring process. Our testing equipment can be used with both mobile and stationary systems. Users can select from systems that operate anywhere from two to forty channels. Our equipment can record manually or via triggered values (in other words, data collection is only started when certain values meet the test criteria or when certain conditions are met). Our equipment also allows you to safely and easily transfer data in real-time, using a wireless connection.

Hydrotechnik's diagnostic test equipment allows you to easily display your data in graph format, create test protocols or display testing and sampling specifications. No programming knowledge is required!

Our equipment is user-friendly and easily adaptable to any configuration, letting you record virtually any number of variables. We have user-friendly devices for every situation, from basic models to mobile devices that do it all.

HYDROTECHNIK DIAGNOSTIC TEST EQUIPMENT: A FAMILY BY DESIGN

The ultimate diagnostic solution!

- No more standalone devices
- Tailored to meet your specifications
- Compatible with your system
- Adaptable to any configuration
- Lets you add on to existing test devices

A sound investment

- We have diagnostic test equipment for any task
- Only buy what you need
- Need to scale up? No problem!
- Single source technology means no compatibility issues
- Compatible with other systems & sensors

Invest for the future

- Free firmware updates
- Open architecture makes upgrading easy
- Calibrate the equipment to meet your needs
- Robust and long-lasting

A partner you can count on

- We have 50 years of market presence
- Our expertise is industrial diagnostic technology
- Research and development are our focus

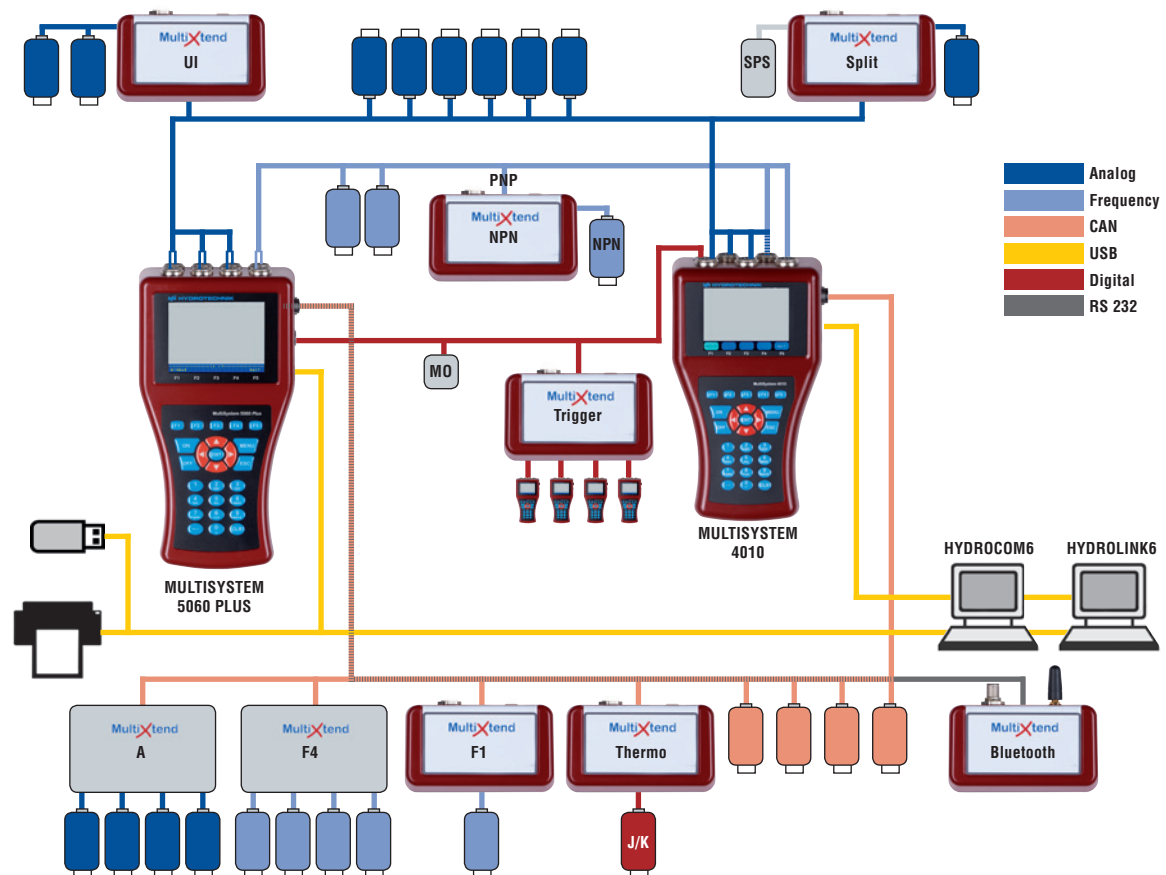



INTRODUCING OUR LINE OF PROFESSIONAL DIAGNOSTIC TEST EQUIPMENT

MULTI HANDY 2025

- 2 channels (switch between analog channels)
- 1 dedicated channel for calculations, i.e. differential pressure or output
- Memory capacity: run up to 5 measurements, with up to 120,000 readings per run
- 2.5" LCD display (optimized for outdoor use)
- 10 hour battery life
- Run a wide range of industrial tests
- User-friendly ISDS plug and play
- Comes with HYDROcom6 BASE / HYDROlink6 BASE software
- Test kit is configurable with various pressure sensors



MULTI HANDY 3020

- 3 channels (2 analog; 1 frequency input)
- 1 dedicated channel for calculations; i.e. differential pressure or output
- Memory capacity: run up to 14 measurements, with up to 1,000,000 readings per run
- 2.1" LCD display
- 16 hour battery life
- Robust aluminum housing
- Comes with HYDROcom6 BASE / HYDROlink6 BASE software
- Test kits are configurable with various pressure, temperature and flow rate sensors as well as other types
- Full kit comes with HYDROcom6 ADVANCED software

MULTI SYSTEM 4010

- 12 channels (3 analog; 1 frequency input; 1 analog/frequency input; 2 digital; 5 CAN channels)
- 5 programmable channels, for CAN, "Patrick" (particle counter), and various calculations, i.e. differential pressure or output
- Memory capacity: run up to 100 measurements, with up to 1,000,000 readings per run
- 3.5" TFT LCD color screen lets you display line graphs and zoom in
- 6 hour battery life

Introducing our high end diagnostic test equipment

- Includes HYDROcom6 ADVANCED / HYDROlink6 BASE software
- Test kits are configurable with various pressure, temperature and flow rate sensors as well as other types





WE HAVE SYSTEMS THAT DO IT ALL!
FROM MOBILE EQUIPMENT TO
HIGH END SYSTEMS

MULTI SYSTEM 5060 PLUS

- 24 channels (6 analog (2 are high speed); 2 frequency input; 2 digital; 14 CAN channels)
- 14 channels, for CAN, "Patrick" (particle counter), and various formulas and calculations
- Memory capacity: run up to 200 measurements with up to 2,000,000 readings per run
- 4.1" TFT LCD color screen lets you display line graphs and zoom in
- 8 hour battery life

the mobile solution that does it all!



- Supports automated test processes
- Wireless Bluetooth data transfer
- Can measure viscosity compensated flow
- Comes with HYDROcom6 ADVANCED / HYDROlink6 BASE software
- Test kits are configurable with various pressure, temperature and flow rate sensors as well as other types
- Test kit includes HYDROcom6 ADVANCED software



MULTI SYSTEM 8050

- 40 channels (12 analog (2 are high speed); 2 analog output; 4 frequency input; 8 digital; 14 CAN channels)
- 14 programmable channels, for CAN, "Patrick" (particle counter), and various formulas and calculations
- Memory capacity: run up to 200 measurements, with up to 6,000,000 readings per run
- 10.4" TFT color touch screen lets you display line graphs and zoom in

High End diagnostic test systems

- Supports automated test processes, including, for example, activating pumps or valves
- Works with your proportional control system to collect data
- Includes HYDROcom6 PROFESSIONAL / HYDROlink6 BASE software
- Black box model has no display, but has the same properties and operated via HYDROlink6 ADVANCED software for use with PCs or laptops.



ADD-ONS

PATRICK

The particle monitor measures contamination levels as well as fluid purity, allowing you to more accurately schedule maintenance and repairs, thereby reducing down time. Patrick can be used as a stand-alone unit or as an integral part of your diagnostic test equipment.



SEG 1060

SEG 1060 is a single-channel diagnostic test device that can be built into your control panel and is available with either analog or digital output. It works with Hydrotechnik's sensors as well as standard sensors and can easily be built into your system. It has a large, digital display, just four buttons, and an easy-to-use interface.



MULTIXTEND

The MultiXtend line of products consists of handy add-ons that complement and add to the functionality of your Hydrotechnik diagnostic test equipment. With MultiXtend units, you can add sensors with analog or frequency input signals, test electrical current, or add thermocouples. MultiXtend increases the diagnostic power of your test equipment.



MultiXtend UI allows you to transform voltage and current to the standardized signal (0 ... 20 mA), used by most of the Hydrotechnik diagnostic test devices. It comes equipped with a switchable filter for PWM signals.

Range:

- MultiXtend UI ± 30 VDC / ± 2 A DC
- MultiXtend UI ± 60 VDC / ± 4 A DC

MultiXtend Bluetooth

This product consists of two units, the MultiXtend device and a data stick, which allows you to connect wirelessly to a MultiSystem 5060Plus and a PC or laptop. The signal is detected automatically, as soon as both devices have been switched on. The maximum range is between 150 m and 200 m.



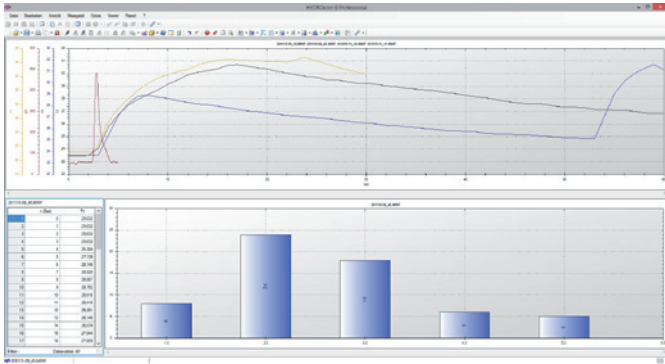

HYDRocom6

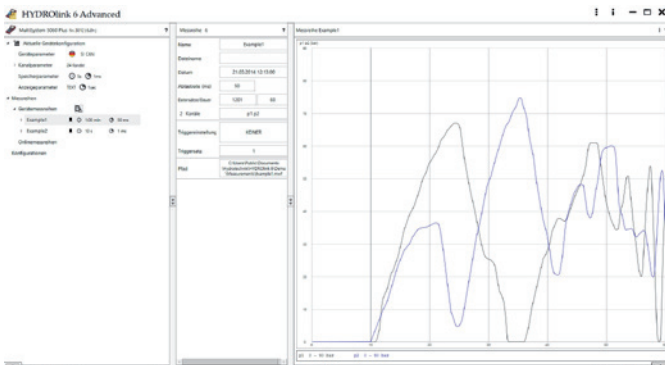

HYDRolink 6 Advanced

Produkte zum Download	Details
Messgerät 6.8h	Verbindung <input checked="" type="checkbox"/> Verbunden
HYDRocom 6 6.3.1.56	Messgerät MultiSystem 5060 Plus 6.8h
Hydrolink 6 6.1.0.25	Firmware Die installierte Firmwareversion ist aktuell
	Anleitung Download ist verfügbar
	Datenblatt Download ist verfügbar
	Manuelle Installation der Firmware

DIE LIZENZ ZUM ERFOLGREICHEN MESSSEN
www.agent2025.com

Eine Verbindung zum Downloadserver ist hergestellt.

HYDRocenter

SOFTWARE

Hydrotechnik develops its own software, designed to be used with Hydrotechnik diagnostic test devices to meet your test data evaluation needs.

HYDRocom6

With HYDRocom6 you can:

- Transfer, import and export data
- Evaluate, analyze and process data
- Transform your data into graphs, tables, histograms
- Create test reports, test protocols or quality control reports
- HYDRocom6 BASE is free with the purchase of any Hydrotechnik diagnostic test device or system

HYDRolink6

Use HYDRolink6 to:

- Run Hydrotechnik diagnostic test equipment on-site or remotely via your laptop or PC
- Access all test equipment functionalities

HYDRocenter

With HYDRocenter you can:

- Get firmware updates automatically
- Get software updates automatically
- Access up-to-date user guides and technical data sheets

HYDRogen

HYDRogen's graphical user interface lets you

- program bespoke test runs, i.e. product series testing, standardized troubleshooting and maintenance tasks.
- No programming experience necessary.

HYDRorun

- Run programmed test runs created with HYDRogen
- Maintain testing procedures
- Control your test run

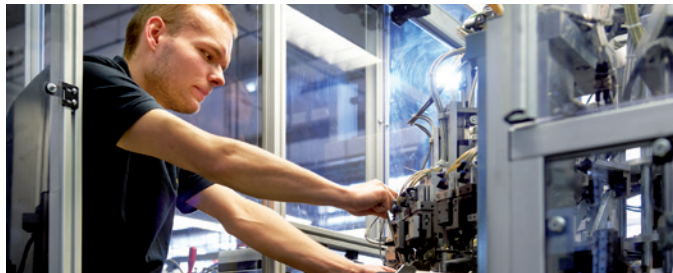

www.hydrotechnik.com

LOCATIONS

Hydrotechnik GmbH
Holzheimer Str. 94-96
D 65549 Limburg

Phone +49 (0) 6431 400 40
Fax +49 (0) 6431 453 08
Email info@hydrotechnik.com
Website www.hydrotechnik.com

SUBSIDIARIES

HYDROTECHNIK France S.A.S.
Europarc
6, Allée des Saules
94000 Créteil

Phone +33 (0) 141 94 51 60
Fax +33 (0) 141 94 51 61
Email contact@hydrotechnik.fr

Hydrotechnik Italia S.r.L.
Via Trento, 59
21047 Saronno (VA)

Phone +39 (0) 296 70 81 32
Fax +39 (0) 296 36 95 11
Email info@hydrotechnik.it

Hydrotechnik Measurement Technology
(Shanghai) Co. Ltd.
Room 7302-B, No. 7 Building
3539 Dongfang Rd.
200125 Shanghai

Phone +86 212 206 2611
Fax +86 215 089 5848
Email info@hydrotechnik-china.com

Hydrotechnik USA Inc.
109 Nicholson Road
Sewickley, PA 15143

Phone +1 412 749 9326
Fax +1 412 749 9325
Email info-us@hydrotechnik.com



 **HYDROTECHNIK**